



EVS 100 ED

Air inlet temperature	°C	0	Evaporating temperature	°C	-10.0
TD	°C	10.0	Refrigerant		R404A
Min number of units in room		1			

Heat exchanger	Standard	Casing	Standard
Motorfans feed	Standard	Fan motors	Standard
Defrost	Electric		

Capacity	kW	0.787			
TD	°C	10.0	Tot. air flow	m3/h	580

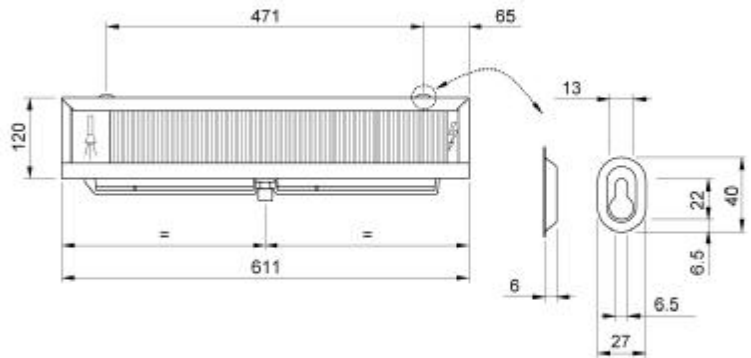
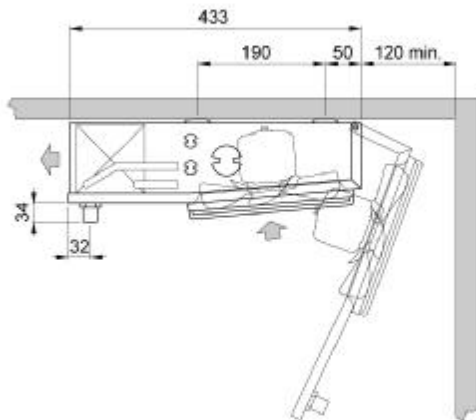

Weight	kg	6.700			
Internal surface	m2	0.24	External surface	m2	2.80
Input connection		10 mm	Output connection		10 mm
Total circuit capacity	dm3	0.54	Fin spacing	mm	3.5 / 7
Drain connection		1/2" GAS			

Defrost	ED	Electric	Total absorption	Watt	650
Fan	n.	2	Diameter	mm	200
Air flow	m3/h	580	Air throw	m	5.0
Feed	V	Standard	Fan speed	rpm	1300
Total absorption	A	0.7	Total power	Watt	106
Tot. Pres.S.Lev. 10 m.	dB(A)	35			