

User

Kubitech S.R.L.

Verification Unit cooler

vineri.17.03.2017

Air inlet temperature	°C	0	Evaporating temperature	°C	-10,0
TD	°C	10,0	Refrigerant		R404A
Min number of units in room		1			

Heat exchanger	Standard	Casing	Standard
Motorfans feed	Standard	Fan motors	Standard
Defrost	Electric		

Selected model: 1 x CTE 194M6 ED

Capacity	kW	13,331			
TD	°C	10,0	Tot. air flow	m3/h	6260

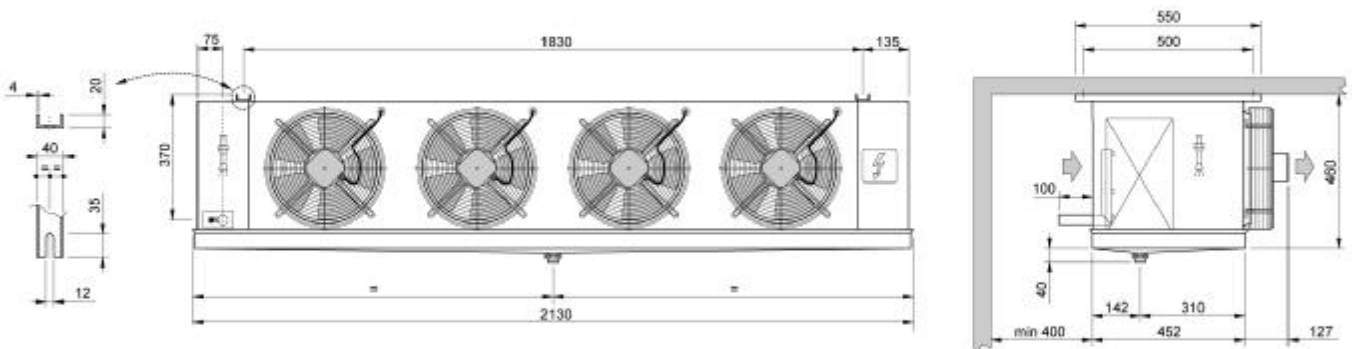

Weight	kg	71,400			
Internal surface	m2	6,11	External surface	m2	38,52
Input connection		5/8" SAE	Output connection		28 mm
Total circuit capacity	dm3	11,08	Fin spacing	mm	6
Drain connection		1" GAS			
Defrost	ED	Electric		Watt	5250
Fan	n.	4	Diameter	mm	315
Air flow	m3/h	6260	Air throw	m	19,0
Feed	V	230/1/50-60	Fan speed	rpm	1370
Fan	A	2,02	Total power	Watt	440
Tot. Pres.S.Lev. 10 m.	dB(A)	45			

N.B.: we shall not be liable for the performances and the quality of sold products, if fitted or connected to fan motor speed regulation or control systems that are different from the ones proposed or installed by us.