

User

Kubitech S.R.L.

Verification Unit cooler

vineri.17.03.2017

Air inlet temperature	°C	0	Evaporating temperature	°C	-10,0
TD	°C	10,0	Refrigerant		R404A
Min number of units in room		1			

Heat exchanger	Standard	Casing	Standard
Motorfans feed	Standard	Fan motors	Standard
Defrost	Electric		

Selected model: 1 x CTE 355A6 ED

Capacity	kW	29,794			
TD	°C	10,0	Tot. air flow	m3/h	11590

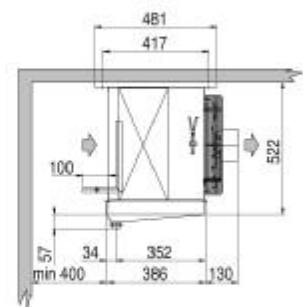
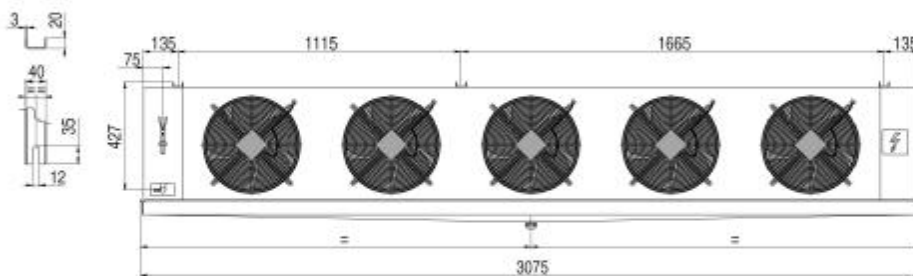

Weight	kg	130,000			
Internal surface	m2	13,81	External surface	m2	79,00
Input connection		22 mm	Output connection		42 mm
Total circuit capacity	dm3	24,30	Fin spacing	mm	6
Drain connection		1" GAS			
Defrost	ED	Electric		Watt	9900
Fan	n.	5	Diameter	mm	350
Air flow	m3/h	11590	Air throw	m	22,0
Feed	V	230/1/50-60	Fan speed	rpm	1450
Fan	A	3,4	Total power	Watt	725
Tot. Pres.S.Lev. 10 m.	dB(A)	52			

N.B.: we shall not be liable for the performances and the quality of sold products, if fitted or connected to fan motor speed regulation or control systems that are different from the ones proposed or installed by us.