

Compresseur / Compressor  
Code tension / Voltage code : T

# TAG4543Y

Froid commercial et industriel positif (HP)  
Commercial & industrial application (HBP)

400-440V / 50-60Hz - 3~

## R134a

## N° 217JU-T - ind g

Conditions Conditions	fréquence frequency	Prod frigorifique nominale / nominal refrigerating capacity			Puis. sonore Sound level
		Watts	Kcal/h	BTU/h	
Standard	50 Hz	9812	8438	33459	ISO 3745 / ISO 3743-1
Standard	60 Hz	11531	9917	39321	
					74 dBA

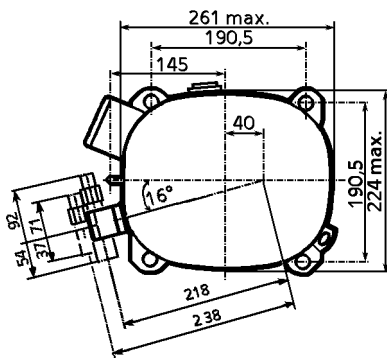
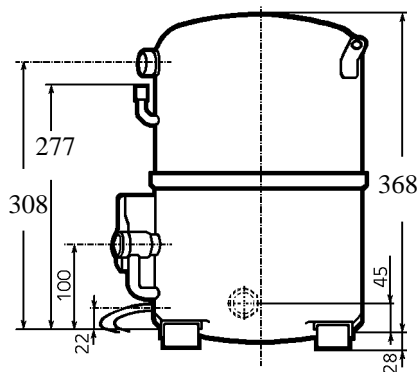

**Cylindrée / Displacement :** 124.4 cm<sup>3</sup>  
**Poids net / Net weight :** 44 Kg  
**Charge en huile / Oil charge :** 1960 cm<sup>3</sup>  
**Type d'huile / Oil type :** P.O.E /  
**Détente / Expansion device :** Capillaire/Détendeur  
*Capillary/Exp° valve*  
**Refroidissement / Cooling :** Ventilé / *Forced*

**Résistance à 20° C / Windings resistances at 20° C**  
 Phases 1,2,3. / *Phase Nr 1,2,3 :* 4.6 Ohms

**Intensité / Current**  
 nom. / *Rated current RLA :* 5.5 / 6.4 A  
 max. / *Max current :* 10.7 / 10.5 A  
 dém. / *Start current LRA :* 42 / 43 A

**Ap. Electrique / Electrical equipment :** TRI

**Protecteur / Overload :** Interne / *Internal*

Le compresseur est livré avec voyant d'huile et réchauffeur de carter.  
 Compressor is delivered with oil sight glass and crankcase heater.

Pour conduites Ø ext / *For tubing O.D.*

Aspiration Suction	Refoulement Discharge	Charge Process
22.2 (7/8")	15.9 (5/8")	6.35 (1/4")

Les caractéristiques données dans cette fiche technique peuvent évoluer sans avis préalable, avec les améliorations que 'Tecumseh' entend toujours apporter à sa production.  
 'Tecumseh', in a constant endeavour to improve its products reserves the right to change any information contained in this leaflet without prior warning.



**Tecumseh**

<b>TAG4543Y</b>	<b>Tension T : 400V 3~ 50Hz / 440V 3~ 60 Hz</b>	<b>R134a</b>	<b>N°217JU-T</b>	<b>Ind g</b>
-----------------	---	--------------	------------------	--------------

Les performances sont données dans les **conditions Standard TE** :  
 Surchauffe : 11°K  
 Sous refroidissement : 8.3°K

The performance data are in **Standard TE conditions** :  
 Superheat : 11°K  
 Subcooling : 8.3°K

### 50 Hz R134a

4  T condensation	5  T évaporation (°C)		-25	-20	-15	-10	-5	0	5	10	15
<b>40</b>	1   P frigorigère (W)		2059	2538	3440	4764	6511	8680	11271	14284	17720
	2   P absorbée (W)		950	1336	1705	2055	2387	2700	2996	3273	3532
	3   I absorbée (A)		2.72	3.14	3.57	4	4.43	4.86	5.29	5.72	6.16
<b>50</b>	1   P frigorigère (W)			1977	2723	3852	5364	7259	9537	12197	15240
	2   P absorbée (W)			1327	1717	2106	2493	2879	3264	3647	4030
	3   I absorbée (A)			3.14	3.58	4.04	4.53	5.05	5.59	6.16	6.75
<b>55</b>	1   P frigorigère (W)				2364	3396	4791	6549	8669	11153	14000
	2   P absorbée (W)				1723	2131	2546	2968	3398	3835	4279
	3   I absorbée (A)				3.58	4.07	4.59	5.15	5.74	6.38	7.05
<b>60</b>	1   P frigorigère (W)				2006	2940	4217	5838	7802	10110	12760
	2   P absorbée (W)				1729	2156	2599	3057	3532	4022	4528
	3   I absorbée (A)				3.59	4.09	4.64	5.24	5.89	6.59	7.35

### 60 Hz R134a

4  T condensation	5  T évaporation (°C)		-25	-20	-15	-10	-5	0	5	10	15
<b>40</b>	1   P frigorigère (W)		2397	3006	4096	5667	7719	10251	13265	16759	20734
	2   P absorbée (W)		1208	1655	2099	2539	2976	3408	3837	4263	4685
	3   I absorbée (A)		2.54	2.98	3.47	3.99	4.56	5.17	5.81	6.5	7.23
<b>50</b>	1   P frigorigère (W)			2338	3242	4582	6360	8573	11223	14310	17834
	2   P absorbée (W)			1650	2115	2601	3107	3634	4182	4750	5339
	3   I absorbée (A)			2.99	3.48	4.04	4.67	5.37	6.15	7	7.91
<b>55</b>	1   P frigorigère (W)				2815	4040	5680	7734	10203	13086	16383
	2   P absorbée (W)				2123	2632	3173	3747	4354	4994	5666
	3   I absorbée (A)				3.49	4.06	4.72	5.48	6.31	7.24	8.26
<b>60</b>	1   P frigorigère (W)				2388	3498	5000	6895	9182	11861	14933
	2   P absorbée (W)				2131	2662	3239	3860	4526	5237	5993
	3   I absorbée (A)				3.49	4.08	4.78	5.58	6.48	7.49	8.6

1 = refrigerating capacity      2 = watt input      3 = current      4 = condensing temperature      5 = evaporating temperature

Nota : Les caractéristiques données dans cette fiche technique peuvent évoluer sans avis préalable, avec les améliorations que "Tecumseh" entend toujours apporter à sa production.

Note : "Tecumseh", in a constant endeavour to improve its products reserves the right to change any information contained in this leaflet without prior warning.