

Input data

Refrigerant	R449A	
Reference temperature	Dew point temperature	
Calculation mode	Refrigeration / Air Cond.	
Operating mode	Subcritical	
Power supply	400/3/50	
Condensing temperature	°C	45
Condensing pressure	bar	18,86
Liquid subcooling	K	0
Liquid temperature	°C	40,72
Evaporating temperature	°C	-10
Evaporating pressure	bar	3,61
Suction gas superheating	K	10
Useful fraction of superheating	%	100

Additional cooling required

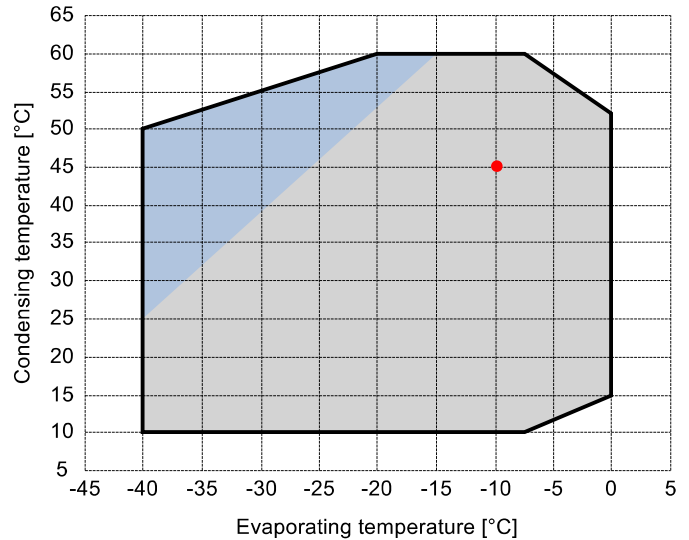

Output data

Compressor :	Z30-126Y	
Number of compressors :	FSx1	
Refrigerating capacity	kW	61,668
Refrigerating capacity [*ref]	kW	63,345
Evaporator capacity	kW	61,668
Power input	W	25922
Condenser capacity, theor.	kW	87,59
Current	A	43,41
COP/EER	W/W	2,38
Mass flow	kg/h	1577
Operating frequency	Hz	50
Connection	-	PWS
Operating mode	-	100%
Discharge temperature	°C	83,86
Ratio (%)	%	100,0%
Note	-	
Oil flow	l/min	-
Heat Exchanged (oil Cooler)	kW	-
Oil Temp. at Oil Cooler Outlet	°C	-
Certified by	-	Frascold

Certified by:

- Frascold tentative data



Legend:

- *ref: At conditions according to EN12900
- Suction gas temperature = 20 °C
- Liquid subcooling = 0 K

All data subject to change without notice

P&I Diagram:

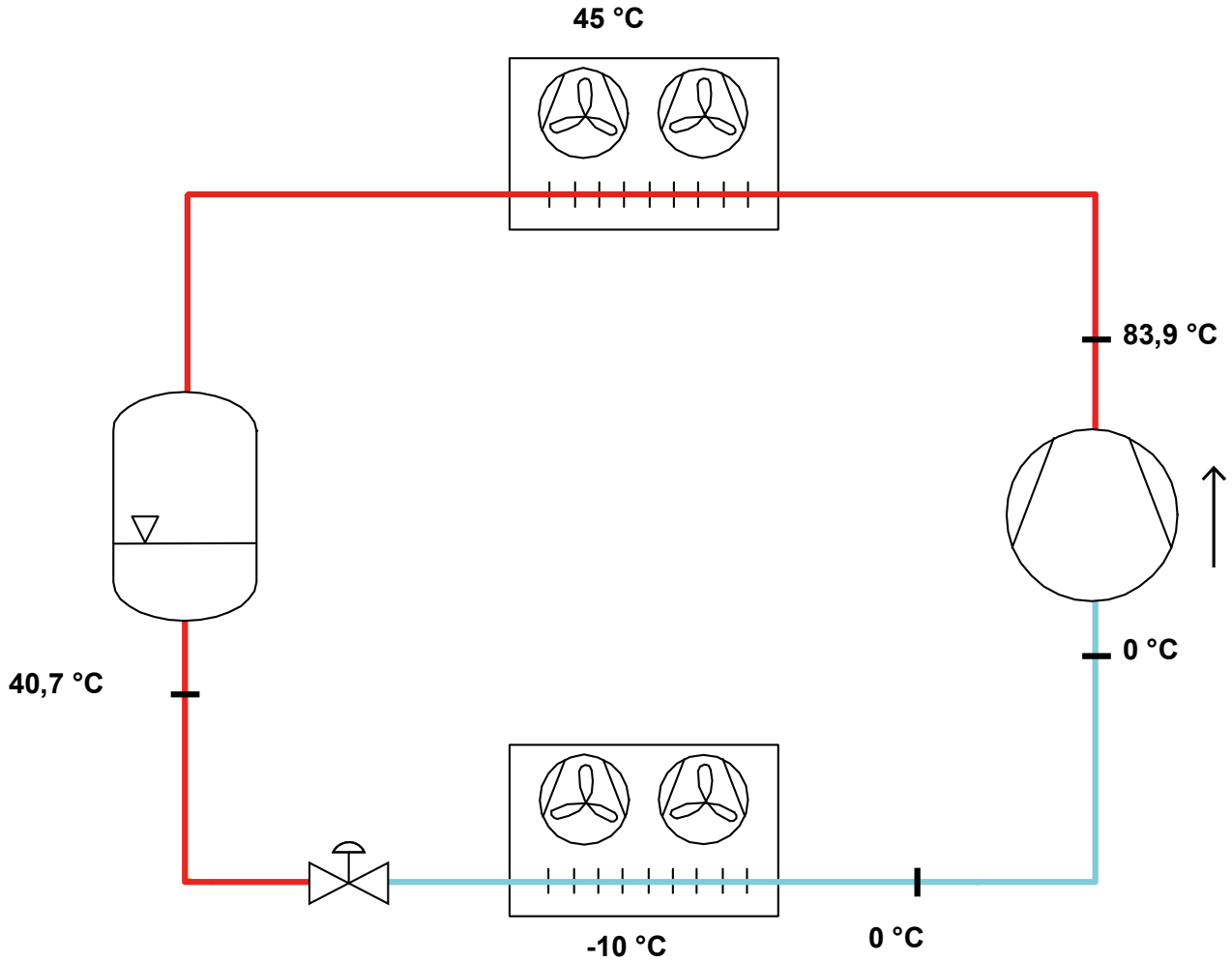

All data subject to change without notice

Model: Z30-126Y

Refrigerant: R449A

Power supply: 400/3/50 PWS

Technical data:

Displacement	125,72 m³/h
Nominal compressor speed	1450 rpm
Motor voltage	400 V
Nominal operating frequency	50 Hz
Maximum allowed operating current (MRA)	55,7 A
Locked rotor current (LRA)	132,6 A
Locked rotor current (LRA), DOL	224,4 A
Number of pistons	6
Net weight	229 kg
Lubricant	FRASCOLD POE68
Oil charge	7,2 l
Maximum static pressure LP	20,5 bar
Maximum operating pressure HP	30 bar

Sound level:

Sound power level -10/45°C R404A @50Hz	83,5 dB(A)
Sound pressure (*) - Distance: 1 m	75,5 dB(A)
Sound power level -35/40°C R404A @50Hz	90,5 dB(A)
Sound pressure (*) - Distance: 1 m	82,5 dB(A)

*half sphere model

Motor connections:

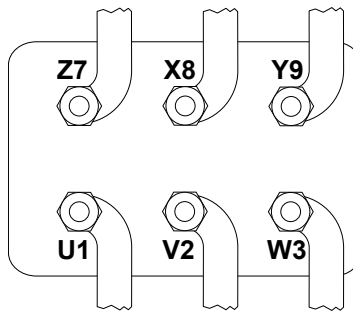

All data subject to change without notice

Model: Z30-126Y

Refrigerant: R449A

Power supply: 400/3/50 PWS

Dimensions:

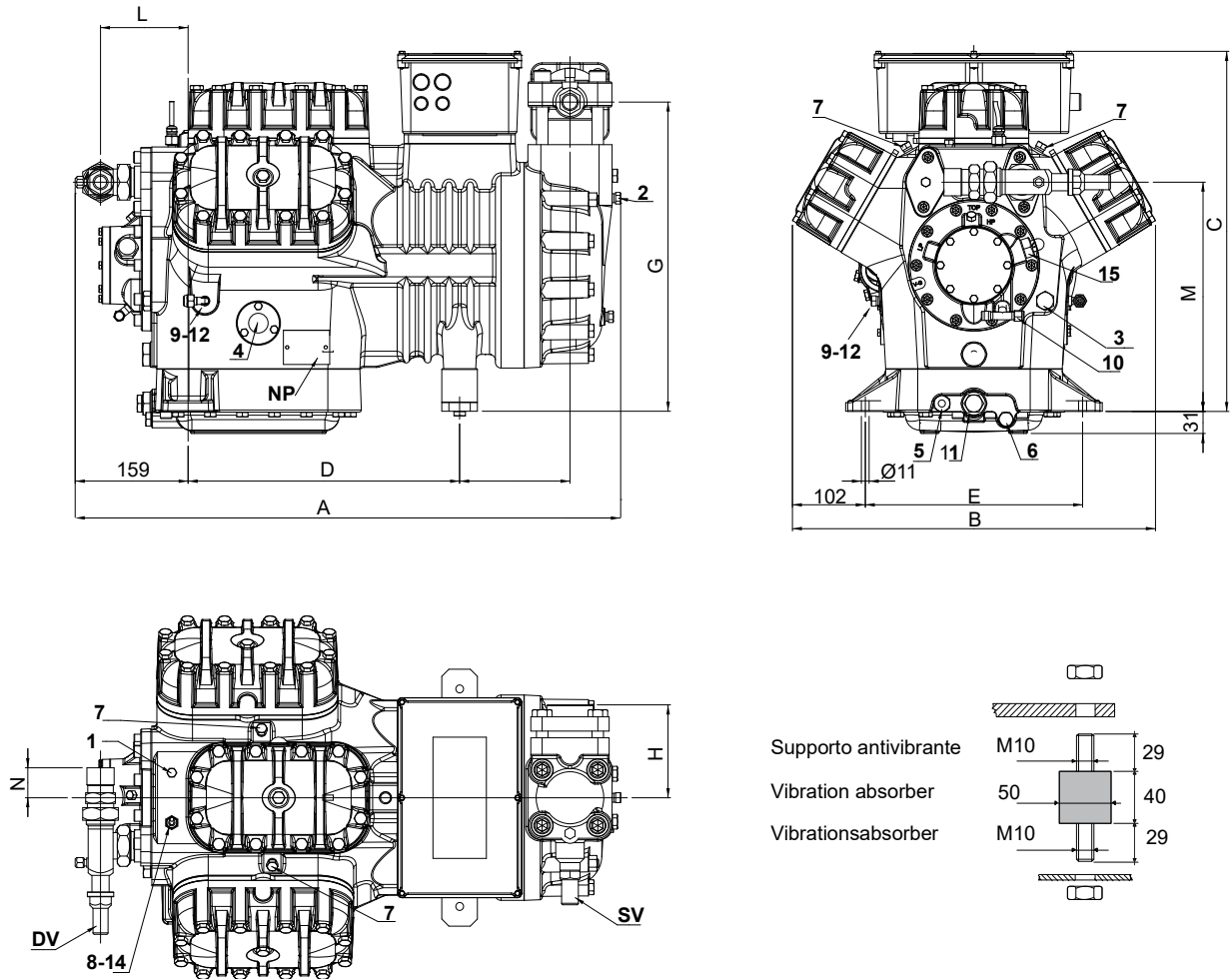

Legend:

SV: Suction Valve	2 1/8" in - 54 mm	2: Low pressure connection	1/4" NPT
DV: Discharge valve	1 3/8" in - 35 mm	3: Oil charge plug	3/8" GAS
A: Length	765 mm	4: Oil level sight glass	-
B: Width	509 mm	5: Crankcase heater seat	-
C: Height	536 mm	6: Oil drain plug	1/4" GAS
D: Base mounting	381 mm	7: Liquid injection plug	1/8" NPT
E: Base mounting	305 mm	8: Liquid injection sensor plug	1/8" NPT
F: Suction Valve	155 mm	9: Oil pressure switch connection (LP)	1/4" NPT
G: Suction Valve	433 mm	10: Oil pressure switch connection (HP)	1/4" SAE
H: Suction Valve	130 mm	11: Oil filter	3/8" GAS
L: Discharge valve	123 mm	12: Oil return plug	1/4" NPT
M: Discharge valve	321 mm	14: Max discharge temperature sensor connection	1/8" NPT
N: Discharge valve	42 mm	15: Electronic oil pressure switch connection	-
1: High pressure connection	1/8" NPT	NP: Nameplate	-

All data subject to change without notice

Model: Z30-126Y

Refrigerant: R449A

Power supply: 400/3/50 PWS

Polynomial coefficients according to EN12900 for Z30-126Y:

*S = T_{evap} ; D = T_{cond}

Reference conditions

Refrigerant	R449A
Ambient temperature	35 °C
Suction gas temperature	20 °C
Liquid subcooling	0 K
Frequency	50 Hz

	Refrigerating capacity [W]	Power input [W]
C1	1,568160E+005	5,396010E+003
C2	5,632840E+003	-4,176820E+002
C3	-1,373950E+003	7,675740E+002
C4	7,188090E+001	-1,170280E+001
C5	-4,541290E+001	2,289930E+001
C6	-1,947440E-001	-5,411910E+000
C7	3,082650E-001	-8,878360E-002
C8	-4,863080E-001	1,436130E-001
C9	-2,173660E-002	-7,984630E-002
C10	-5,355350E-003	2,074840E-002

$$Y = C1 + C2*S + C3*D + C4*S^2 + C5*S*D + C6*D^2 + C7*S^3 + C8*D*S^2 + C9*S*D^2 + C10*D^3$$

All data subject to change without notice