

Input data

Refrigerant	R449A	
Reference temperature	Dew point temperature	
Calculation mode	Refrigeration / Air Cond.	
Operating mode	Subcritical	
Power supply	400/3/50	
Condensing temperature	°C	45
Condensing pressure	bar	18,86
Liquid subcooling	K	0
Liquid temperature	°C	40,72
Evaporating temperature	°C	-10
Evaporating pressure	bar	3,61
Suction gas superheating	K	10
Useful fraction of superheating	%	100

Additional cooling required

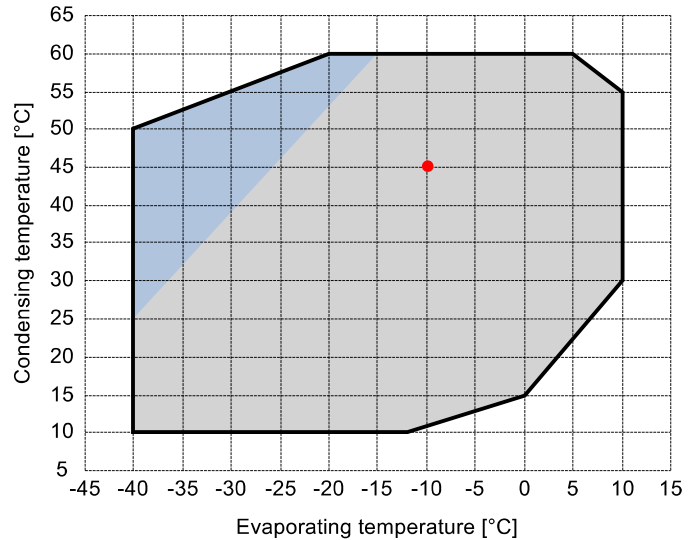

Output data

Compressor :	S15-52Y	
Number of compressors :	FSx1	
Refrigerating capacity	kW	23,08
Refrigerating capacity [*ref]	kW	23,708
Evaporator capacity	kW	23,08
Power input	W	9783
Condenser capacity, theor.	kW	32,863
Current	A	20,76
COP/EER	W/W	2,36
Mass flow	kg/h	590
Operating frequency	Hz	50
Connection	-	PWS
Operating mode	-	100%
Discharge temperature	°C	84,29
Ratio (%)	%	100,0%
Note	-	
Oil flow	l/min	-
Heat Exchanged (oil Cooler)	kW	-
Oil Temp. at Oil Cooler Outlet	°C	-
Certified by	-	Frascold

Certified by:

- Frascold tentative data

Legend:

- *ref: At conditions according to EN12900
- Suction gas temperature = 20 °C
- Liquid subcooling = 0 K

P&I Diagram:

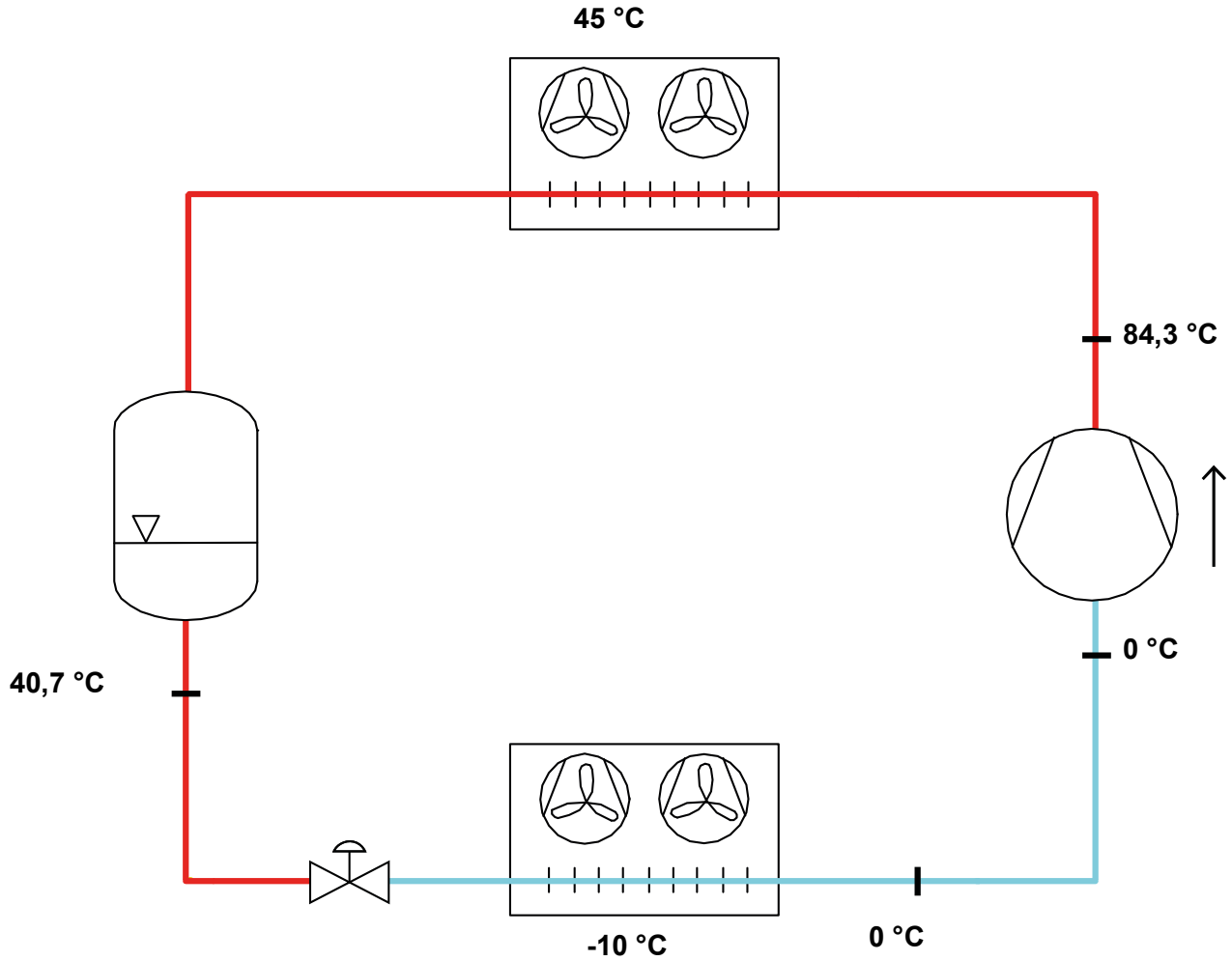

All data subject to change without notice

Model: S15-52Y

Refrigerant: R449A

Power supply: 400/3/50 PWS

Technical data:

Displacement	51,5 m³/h
Nominal compressor speed	1450 rpm
Motor voltage	400 V
Nominal operating frequency	50 Hz
Maximum allowed operating current (MRA)	32,4 A
Locked rotor current (LRA)	74,8 A
Locked rotor current (LRA), DOL	117,1 A
Number of pistons	4
Net weight	126 kg
Lubricant	FRASCOLD POE32
Oil charge	2,9 l
Maximum static pressure LP	20,5 bar
Maximum operating pressure HP	30 bar

Sound level:

Sound power level 5/50°C R404A @50Hz	75,5 dB(A)
Sound pressure (*) - Distance: 1 m	67,5 dB(A)
Sound power level -10/45°C R404A @50Hz	76,5 dB(A)
Sound pressure (*) - Distance: 1 m	68,5 dB(A)

*half sphere model

Motor connections:

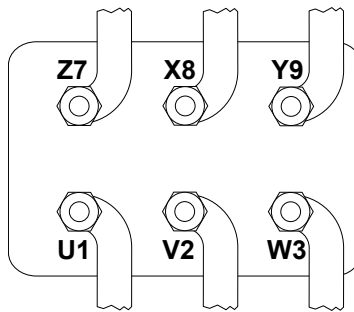

All data subject to change without notice

Model: S15-52Y

Refrigerant: R449A

Power supply: 400/3/50 PWS

Polynomial coefficients according to EN12900 for S15-52Y:

*S = T_{evap} ; D = T_{cond}

Reference conditions

Refrigerant	R449A
Ambient temperature	35 °C
Suction gas temperature	20 °C
Liquid subcooling	0 K
Frequency	50 Hz

	Refrigerating capacity [W]	Power input [W]
C1	6,849150E+004	2,943410E+003
C2	2,625890E+003	-1,566080E+002
C3	-7,346690E+002	1,975170E+002
C4	3,670160E+001	-4,770680E+000
C5	-2,306180E+001	6,686600E+000
C6	1,237090E+000	8,259710E-001
C7	1,862480E-001	-3,862580E-002
C8	-2,387210E-001	1,894230E-002
C9	5,980200E-003	-9,690150E-003
C10	-6,977080E-003	-2,328070E-002

$$Y = C1 + C2*S + C3*D + C4*S^2 + C5*S*D + C6*D^2 + C7*S^3 + C8*D*S^2 + C9*S*D^2 + C10*D^3$$