

Input data

Refrigerant	R449A	
Reference temperature	Dew point temperature	
Calculation mode	Refrigeration / Air Cond.	
Operating mode	Subcritical	
Power supply	400/3/50	
Condensing temperature	°C	45
Condensing pressure	bar	18,86
Liquid subcooling	K	0
Liquid temperature	°C	40,72
Evaporating temperature	°C	-10
Evaporating pressure	bar	3,61
Suction gas superheating	K	10
Useful fraction of superheating	%	100

Additional cooling required

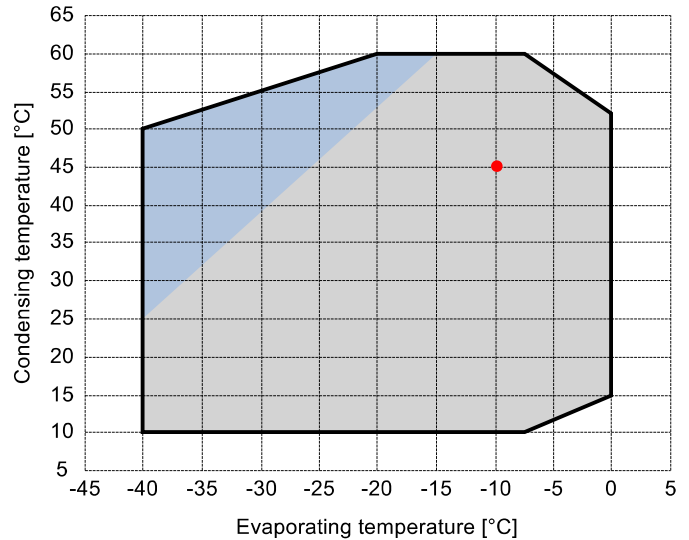

Output data

Compressor :	S8-42Y	
Number of compressors :	FSx1	
Refrigerating capacity	kW	19,296
Refrigerating capacity [*ref]	kW	19,821
Evaporator capacity	kW	19,296
Power input	W	8222
Condenser capacity, theor.	kW	27,518
Current	A	14,13
COP/EER	W/W	2,35
Mass flow	kg/h	494
Operating frequency	Hz	50
Connection	-	PWS
Operating mode	-	100%
Discharge temperature	°C	84,57
Ratio (%)	%	100,0%
Note	-	
Oil flow	l/min	-
Heat Exchanged (oil Cooler)	kW	-
Oil Temp. at Oil Cooler Outlet	°C	-
Certified by	-	Frascold

Certified by:

- Frascold tentative data

Legend:

- *ref: At conditions according to EN12900
- Suction gas temperature = 20 °C
- Liquid subcooling = 0 K

P&I Diagram:

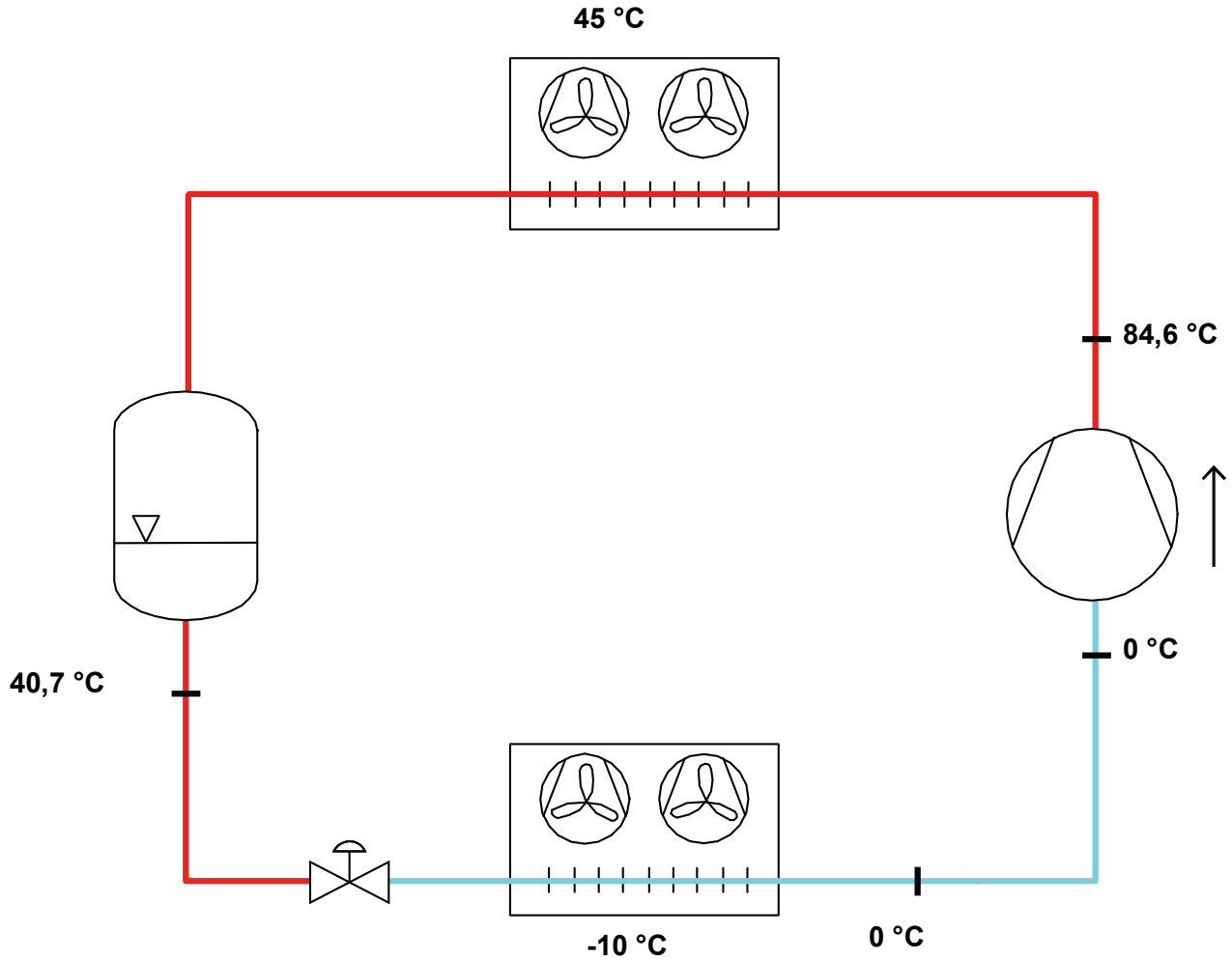

All data subject to change without notice

Model: S8-42Y

Refrigerant: R449A

Power supply: 400/3/50 PWS

Technical data:

Displacement	41,32 m³/h
Nominal compressor speed	1450 rpm
Motor voltage	400 V
Nominal operating frequency	50 Hz
Maximum allowed operating current (MRA)	20,3 A
Locked rotor current (LRA)	52,7 A
Locked rotor current (LRA), DOL	90,3 A
Number of pistons	4
Net weight	117 kg
Lubricant	FRASCOLD POE32
Oil charge	2,9 l
Maximum static pressure LP	20,5 bar
Maximum operating pressure HP	30 bar

Sound level:

Sound power level -10/45°C R404A @50Hz	75 dB(A)
Sound pressure (*) - Distance: 1 m	67 dB(A)
Sound power level -35/40°C R404A @50Hz	79,5 dB(A)
Sound pressure (*) - Distance: 1 m	71,5 dB(A)

*half sphere model

Motor connections:

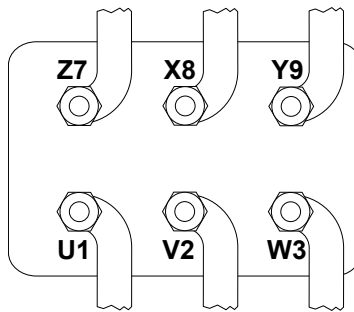

All data subject to change without notice

Model: S8-42Y
Refrigerant: R449A
Power supply: 400/3/50 PWS

Dimensions:

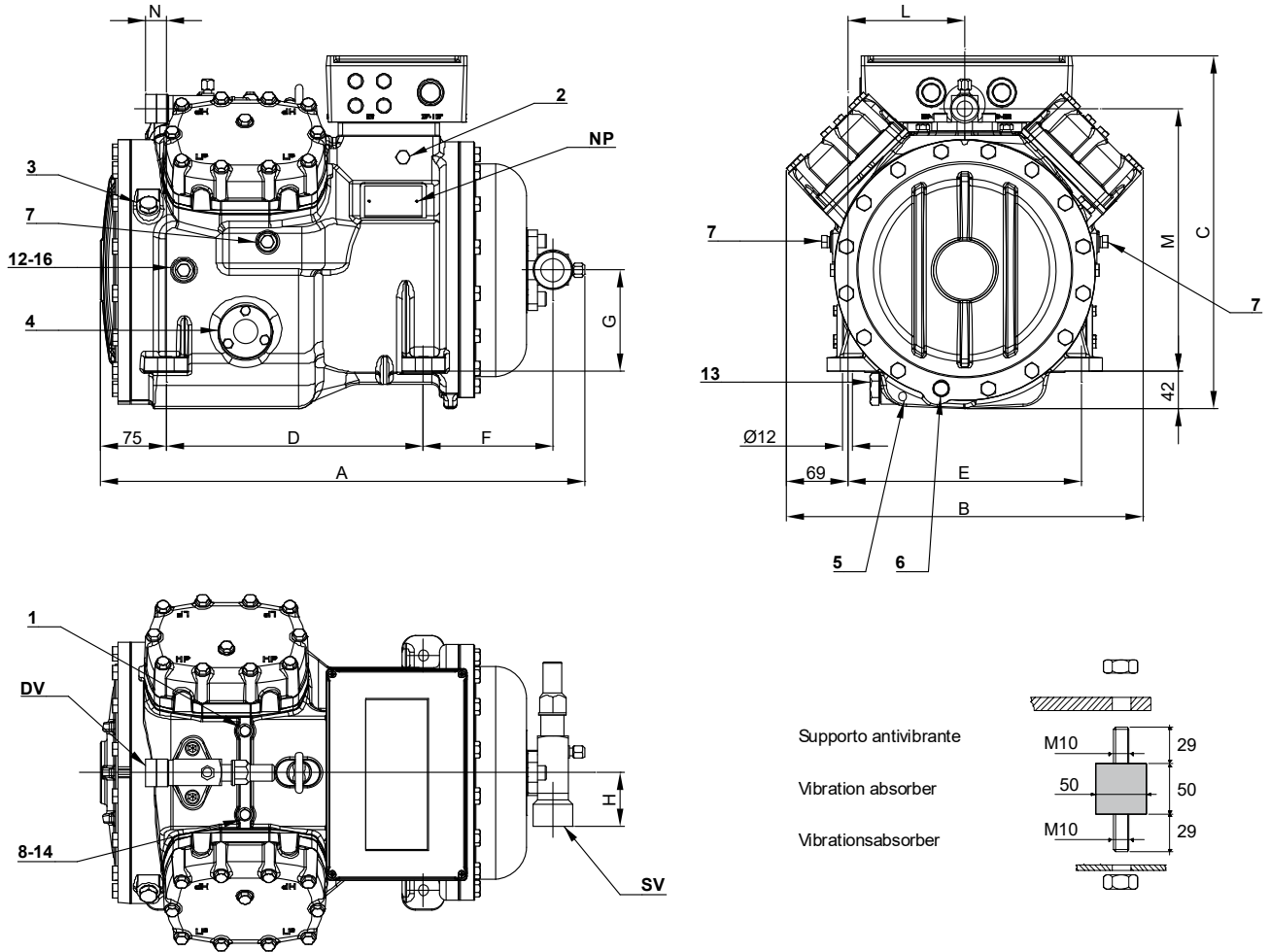

Legend:

SV: Suction Valve	1 3/8" in - 35 mm	1: High pressure connection	1/8" NPT
DV: Discharge valve	1 1/8" in - 28,575 mm	2: Low pressure connection	1/8" NPT
A: Length	550 mm	3: Oil charge plug	1/4" GAS
B: Width	405 mm	4: Oil level sight glass	-
C: Height	405 mm	5: Crankcase heater seat	-
D: Base mounting	292 mm	6: Oil drain plug	M10 x 30
E: Base mounting	266 mm	7: Liquid injection plug	1/4" NPT
F: Suction Valve	147 mm	8: Liquid injection sensor plug	1/8" NPT
G: Suction Valve	115 mm	12: Oil return plug	1/4" NPT
H: Suction Valve	58 mm	13: Magnetic plug	1/2" GAS
L: Discharge valve	133 mm	14: Max discharge temperature sensor connection	1/8" NPT
M: Discharge valve	298 mm	16: Crankcase pressure plug	1/4" NPT
N: Discharge valve	23 mm	NP: Nameplate	

All data subject to change without notice

Model: S8-42Y

Refrigerant: R449A

Power supply: 400/3/50 PWS

Polynomial coefficients according to EN12900 for S8-42Y:

*S = T_{evap} ; D = T_{cond}

Reference conditions

Refrigerant	R449A
Ambient temperature	35 °C
Suction gas temperature	20 °C
Liquid subcooling	0 K
Frequency	50 Hz

	Refrigerating capacity [W]	Power input [W]
C1	5,454800E+004	1,495540E+003
C2	2,034350E+003	-1,705060E+002
C3	-5,515950E+002	2,497500E+002
C4	2,729100E+001	-4,705470E+000
C5	-1,690670E+001	7,082910E+000
C6	5,663940E-001	-1,762980E+000
C7	1,371250E-001	-2,972100E-002
C8	-1,484170E-001	4,769270E-002
C9	1,433750E-002	-1,158310E-002
C10	5,404860E-004	5,839620E-003

$$Y = C1 + C2*S + C3*D + C4*S^2 + C5*S*D + C6*D^2 + C7*S^3 + C8*D*S^2 + C9*S*D^2 + C10*D^3$$