

Input data

Refrigerant	R449A	
Reference temperature	Dew point temperature	
Calculation mode	Refrigeration / Air Cond.	
Operating mode	Subcritical	
Power supply	400/3/50	
Condensing temperature	°C	45
Condensing pressure	bar	18,86
Liquid subcooling	K	0
Liquid temperature	°C	40,72
Evaporating temperature	°C	-10
Evaporating pressure	bar	3,61
Suction gas superheating	K	10
Useful fraction of superheating	%	100

Additional cooling required

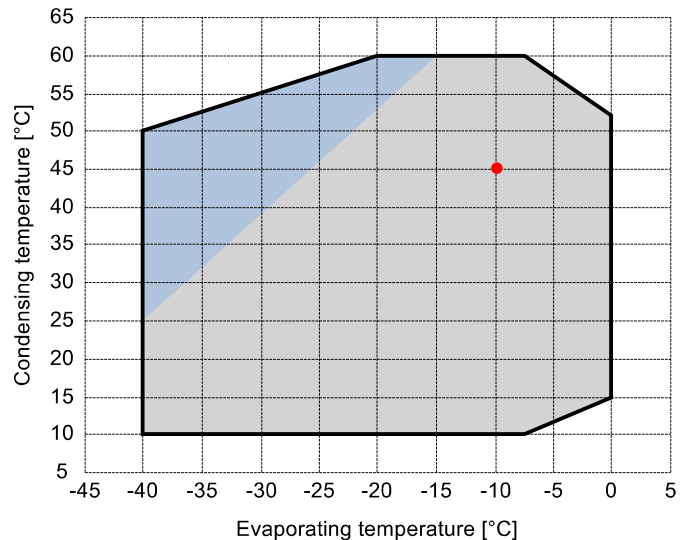

Output data

Compressor :	D4-19.1Y	
Number of compressors :	FSx1	
Refrigerating capacity	kW	9,128
Refrigerating capacity [*ref]	kW	9,377
Evaporator capacity	kW	9,128
Power input	W	4060
Condenser capacity, theor.	kW	13,188
Current	A	8,66
COP/EER	W/W	2,25
Mass flow	kg/h	233
Operating frequency	Hz	50
Connection	-	DOL-STAR
Operating mode	-	100%
Discharge temperature	°C	86,9
Ratio (%)	%	100,0%
Note	-	
Oil flow	l/min	-
Heat Exchanged (oil Cooler)	kW	-
Oil Temp. at Oil Cooler Outlet	°C	-
Certified by	-	Frascold

Certified by:

- Frascold tentative data

Legend:

- *ref: At conditions according to EN12900
- Suction gas temperature = 20 °C
- Liquid subcooling = 0 K

P&I Diagram:

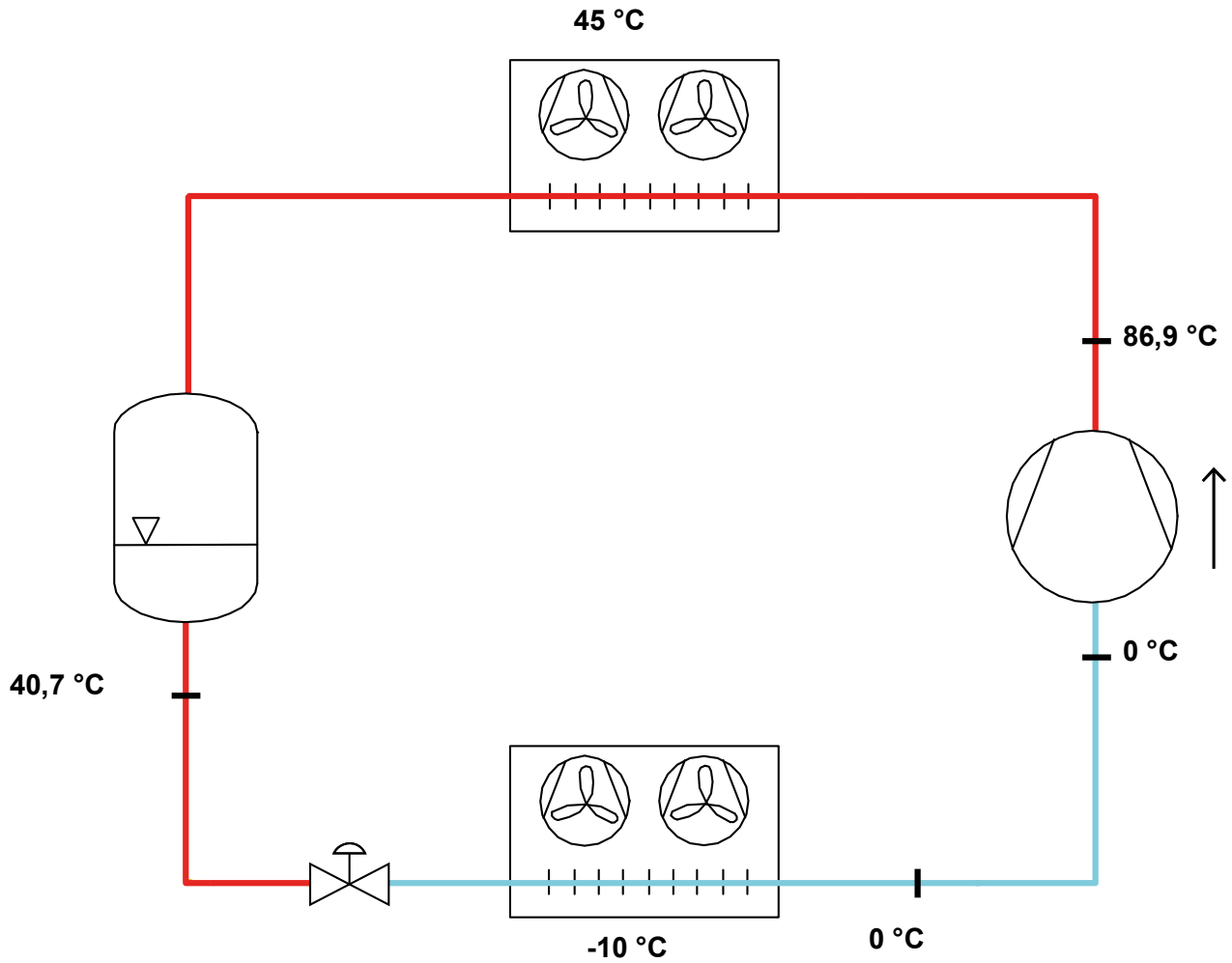

All data subject to change without notice

Model: D4-19.1Y

Refrigerant: R449A

Power supply: 400/3/50 DOL-STAR

Technical data:

Displacement	19,12 m³/h
Nominal compressor speed	1450 rpm
Motor voltage	400 V
Nominal operating frequency	50 Hz
Maximum allowed operating current (MRA)	11,8 A
Locked rotor current (LRA)	52 A
Number of pistons	2
Net weight	55 kg
Lubricant	FRASCOLD POE32
Oil charge	1,2 l
Maximum static pressure LP	20,5 bar
Maximum operating pressure HP	30 bar

Sound level:

Sound power level 5/50°C R404A @50Hz	67,7 dB(A)
Sound pressure (*) - Distance: 1 m	59,7 dB(A)
Sound power level -10/45°C R404A @50Hz	67,2 dB(A)
Sound pressure (*) - Distance: 1 m	59,2 dB(A)

*half sphere model

Motor connections:

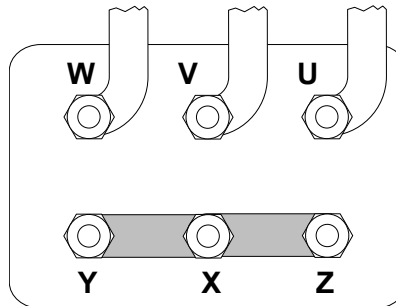

All data subject to change without notice

Model: D4-19.1Y

Refrigerant: R449A

Power supply: 400/3/50 DOL-STAR

Dimensions:

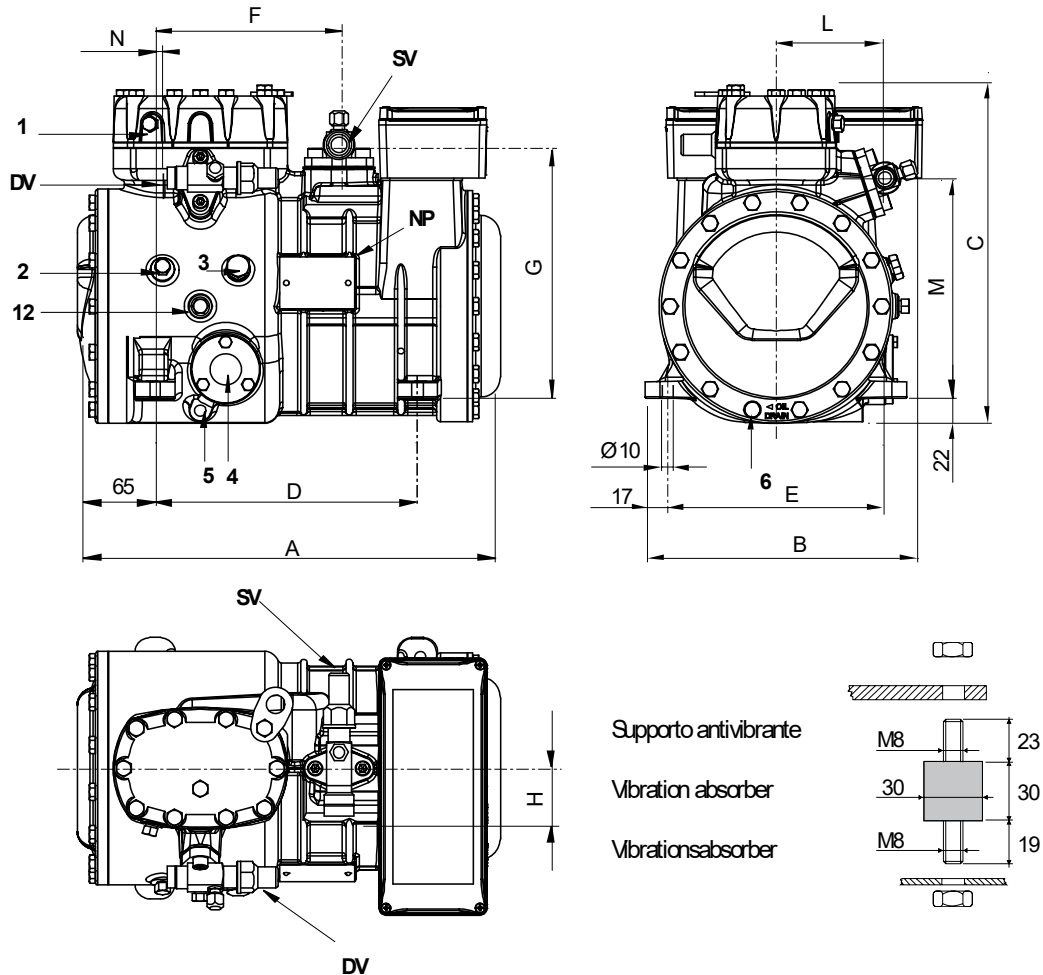

Legend:

SV: Suction Valve	1 1/8" in - 28,575 mm	M: Discharge valve	192 mm
DV: Discharge valve	3/4" in - 19 mm	N: Discharge valve	5 mm
A: Length	401 mm	1: High pressure connection	1/8" NPT
B: Width	242 mm	2: Low pressure connection	1/8" NPT
C: Height	317 mm	3: Oil charge plug	1/4" GAS
D: Base mounting	234 mm	4: Oil level sight glass	-
E: Base mounting	194 mm	5: Crankcase heater seat	-
F: Suction Valve	165 mm	6: Oil drain plug	M8 x 22
G: Suction Valve	225 mm	12: Oil return plug	1/8" NPT
H: Suction Valve	53 mm	NP: Nameplate	
L: Discharge valve	94 mm		

All data subject to change without notice

Model: D4-19.1Y

Refrigerant: R449A

Power supply: 400/3/50 DOL-STAR

Polynomial coefficients according to EN12900 for D4-19.1Y:

*S = T_{evap} ; D = T_{cond}

Reference conditions

Refrigerant	R449A
Ambient temperature	35 °C
Suction gas temperature	20 °C
Liquid subcooling	0 K
Frequency	50 Hz

	Refrigerating capacity [W]	Power input [W]
C1	2,431570E+004	9,087650E+002
C2	9,123650E+002	-7,906670E+001
C3	-2,102610E+002	1,102370E+002
C4	1,252120E+001	-2,451000E+000
C5	-7,056400E+000	3,265830E+000
C6	-3,108500E-001	-5,904000E-001
C7	6,407340E-002	-1,951040E-002
C8	-7,421260E-002	2,212060E-002
C9	-4,716940E-003	-8,016050E-003
C10	1,654500E-003	3,173000E-004

$$Y = C1 + C2*S + C3*D + C4*S^2 + C5*S*D + C6*D^2 + C7*S^3 + C8*D*S^2 + C9*S*D^2 + C10*D^3$$