



Compressor
Voltage Code : XG

FH4524Z-XG

High Temp. Commercial (HP)

380-420V 3~ 50Hz / 460V 3~ 60 Hz

R404A

FH4524Z-XG1A

Operating conditions :	Customized... / 50 Hz / Dew	Sound Power ISO3745 / ISO 3743-1
Evaporating Temp. : 0.00 °C Superheat : 6.50 K Return gas temp. : 0.00 °C Condensing Temp. : 45.0 °C Subcooling : 20.2 K Liquid : 24.5 °C	Refrig. Capacity : 5842 Watt Power Input : 1831 Watt Amps : 3.28 A C.O.P : 3.19 Watt/W	71 dBA

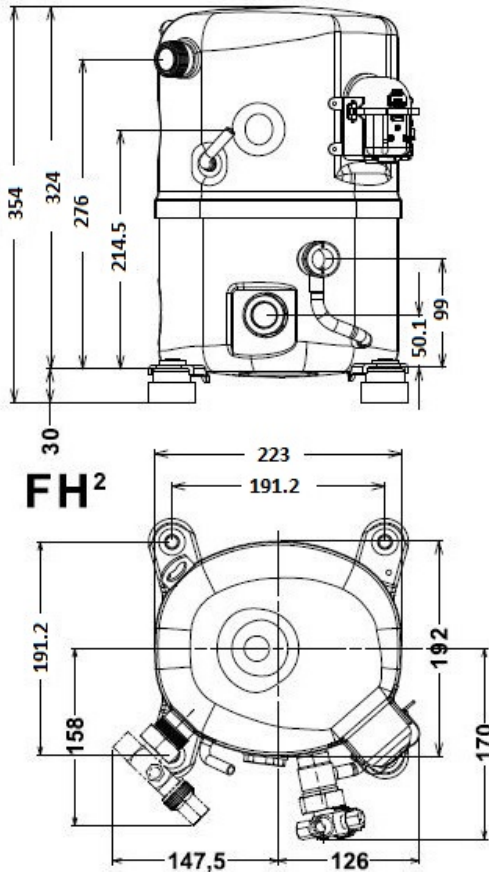

Displacement (cc)	43,3
Net Weight (Kg)	33.0
Oil Quantity (cc)	1140.0
Oil Type	Polyolester
Expansion Device	Capillary_Tube/Expansion_Valve
Cooling	Fan
Main Winding (Ohm)	7.05
Current	
RLA (A)	3.8 3.9
MCC (A)	6.6
LRA (A)	26
Electrical Equipment	TRI
Overload	Interne
Refrigerating connection for	
Suction Tube	15.9 (5/8")
Discharge Tube	12.7 (1/2")
Process Tube	6.35 (1/4")

Certificates :



Note : Tecumseh reserves the right to change information contained in this document without notification.



Tecumseh

FH4524Z-XG	Tension XG : 380-420V 3~ 50Hz / 460V 3~ 60 Hz
-------------------	--

Les performances sont données dans les conditions EN12900 :	Gaz aspirés :	20.0 °C
Condition Dew	Sous refroidissement :	0.0 K
The performance data are in EN12900 conditions :	Return gas :	20.0 °C
Dew Condition	Subcooling :	0.0 K

50 Hz R404A											
											N°User-225
4 T condensation	5 T évaporation	(°C)	-25	-20	-15	-10	-5	0	5	10	15
30	1 P frigorifique	(Watt)	1837	2500	3293	4231	5332	6614	8096	9793	11723
	2 P absorbée	(W)	938	1124	1280	1406	1502	1568	1602	1605	1575
	3 I absorbée	(A)	2.09	2.32	2.52	2.68	2.81	2.90	2.96	2.99	2.98
40	1 P frigorifique	(Watt)	1301	1888	2570	3363	4285	5354	6587	8001	9615
	2 P absorbée	(W)	857	1094	1303	1484	1635	1757	1848	1909	1939
	3 I absorbée	(A)	1.97	2.28	2.55	2.79	3.00	3.17	3.31	3.41	3.49
50	1 P frigorifique	(Watt)		1296	1873	2528	3277	4138	5129	6266	7569
	2 P absorbée	(W)		1026	1285	1516	1720	1894	2040	2156	2242
	3 I absorbée	(A)		2.17	2.52	2.84	3.13	3.37	3.59	3.77	3.92
60	1 P frigorifique	(Watt)			1209	1731	2314	2973	3728	4595	5593
	2 P absorbée	(W)			1236	1516	1768	1993	2190	2359	2498
	3 I absorbée	(A)			2.44	2.83	3.19	3.52	3.81	4.07	4.29

60 Hz R404A											
											N°User-225
4 T condensation	5 T évaporation	(°C)	-25	-20	-15	-10	-5	0	5	10	15
30	1 P frigorifique	(Watt)	2155	3039	4044	5194	6507	8005	9709	11639	13817
	2 P absorbée	(W)	1141	1366	1556	1709	1826	1906	1948	1951	1915
	3 I absorbée	(A)	2.09	2.33	2.53	2.70	2.83	2.92	2.98	3.01	3.01
40	1 P frigorifique	(Watt)	1406	2225	3129	4139	5275	6558	8008	9647	11495
	2 P absorbée	(W)	1042	1330	1585	1804	1988	2136	2247	2321	2357
	3 I absorbée	(A)	1.97	2.29	2.57	2.81	3.01	3.18	3.32	3.43	3.50
50	1 P frigorifique	(Watt)		1410	2202	3060	4007	5063	6248	7584	9092
	2 P absorbée	(W)		1247	1562	1843	2090	2303	2480	2621	2726
	3 I absorbée	(A)		2.18	2.54	2.86	3.15	3.40	3.61	3.79	3.94
60	1 P frigorifique	(Watt)			1318	2014	2760	3578	4487	5508	6663
	2 P absorbée	(W)			1503	1843	2150	2423	2663	2867	3037
	3 I absorbée	(A)			2.46	2.85	3.22	3.54	3.84	4.10	4.33

1 = cooling capacity 2 = power input 3 = current 4 = condensing temperature 5 = evaporating temperature

Nota : Tecumseh se réserve le droit de modifier les informations contenues dans ce document sans préavis.

Note : Tecumseh reserves the right to change information contained in this document without notification.

© 2023 Tecumseh Products Company
All rights reserved