

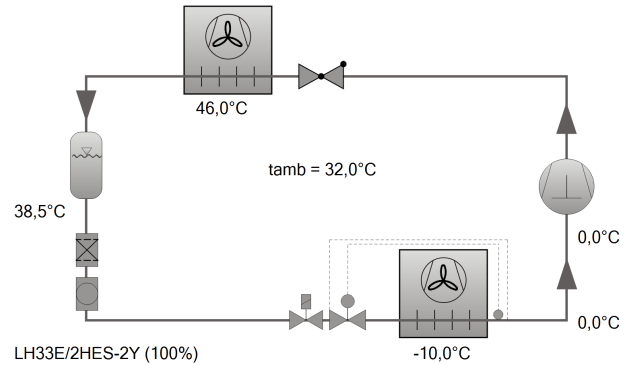

## Selection: Condensing Units

### Input Values

Unit type	LH33E/2HES-2Y
Series	Standard
Refrigerant	R449A
Reference temperature	Dew point temp.
Evaporating SST	-10,00 °C
Ambient temp.	32,0 °C
Suct. gas superheat	10,00 K
Useful superheat	100%
Operating mode	Auto
Power supply	400V-3-50Hz
Capacity control	100%



### Result

Unit type	<b>LH33E/2HES-2Y-40S</b>
Capacity steps	100%
Cooling capacity	2,75 kW
Evaporator capacity	2,75 kW
Power input	1,50 kW
Current (400V)	3,08 A
Voltage range	380-420V
Mass flow	69,0 kg/h
Condensing SDT	46,0 °C
Liquid subcooling	3,00 K
Operating mode	Standard

Tentative Data.

Power input including fan power absorption

### Application Limits 1 LH33E/2HES-2

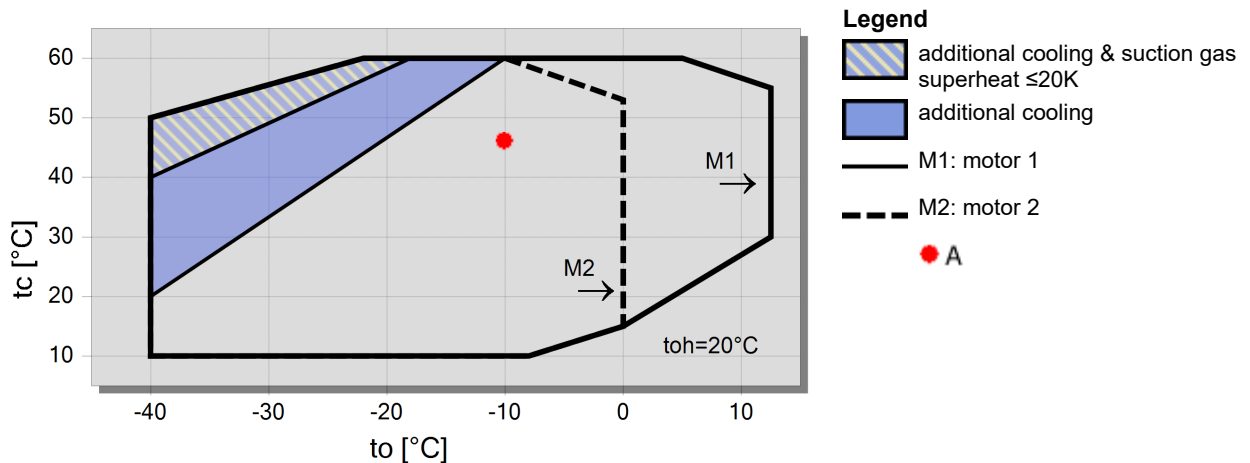



## Technical Data: LH33E/2HES-2Y

### Dimensions and Connections

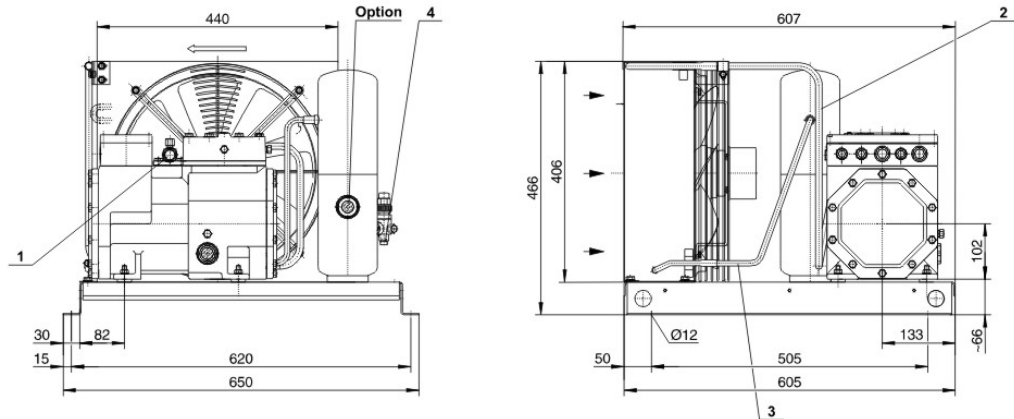

### Technical Data

#### Technical Data

Weight	72 kg
Total width	650 mm
Total depth	607 mm
Total height	466 mm
Connection suction line	16 mm - 5/8"
Connection liquid line	10 mm - 3/8"
Voltage (50Hz, more on request)	230V-1-50Hz (Standard)
Current / Power consumption of each fan (50Hz)	1,4 A / 160 W
Air flow condenser 50Hz	1650 m <sup>3</sup> /h
Voltage (60Hz, more on request)	230V-1-60Hz (Standard)
Current / Power consumption of each fan (60Hz)	1,35 A / 135 W
Air flow condenser 60Hz	1550 m <sup>3</sup> /h
Coil Volume	0,5 dm <sup>3</sup>

#### Extent of delivery (Standard)

Liquid receiver with shut-off valve	Standard
Discharge gas line	Standard
Fans: Number	1 x EC
Protective charge	Standard

#### Available Options

Condenser with improved corrosion protection, plastic coated fins or copper fins	Option
Oil separator with check valve	Option
Accessory pack (HP/LP switches, complete wiring, liquid line + filter drier + sight glass)	Option
Wiring of electrical components to terminal box or junction box	Option
Adjustable high and low pressure switch	Option
Speed control fan, control range high pressure	5 .. 15 bar // 8 .. 25 bar
Oil heater	Option
Liquid receiver with larger volume	Option
Weather protection housing, mounting kit	Option

#### Sound measurement

Data of compressors: see compressor program

#### Max. refrigerant charge 90% at 20°C / 68°F

Receiver type (Standard)	FS36
R22	3,3 kg
R134a	3,3 kg
R407C	3,1 kg
R404A/R507A	2,9 kg
R407A	3,2 kg
R407F	3,1 kg
R448A	3 kg
R449A	3 kg
R450A	3,2 kg
R454C	2,9 kg



R455A	2,9 kg
R513A	3,3 kg
R1234yf	3,0 kg
R1234ze	3,1 kg
Receiver type (Option)	FS056
R22	6,1 kg
R134a	6,2 kg
R407C	5,8 kg
R404A/R507A	5,4 kg



## Condensing Units

**Motor 1** = e.g. LH..E/4TES-12 with 12 "HP", primary for air-conditioning (e.g. R22,R407C) and medium temperature application (e.g. R134a, R407F, R407A, R404A, R507A, R22) and air-conditioning with R134a at high ambient temperatures.

**Motor 2** = e.g. LH..E/4TES-9 with 8 "HP", for medium and low temperature application (e.g. R134a, R407F, R407A, R404A, R507A, R22) and air-conditioning with R134a.

For more information concerning the application range use the "limits" button.

### Operation modes for LH..E/4VES-7 to LH../6HE-28 with R22

CIC = liquid injection with low temperature application, suction gas cooled motor

### Specifications for sound emission

The data are based on 50 Hz operation.

Soundpressure: Data are valid for free field conditions with a block-shaped reference area in a distance of 10m.

For further information see technical information for sound data.

### Legend of connection positions according to "Dimensions":

- 1 Suction gas valve
- 2 Discharge gas line
- 3 Condensate line
- 4 Refrigerant outlet (liquid line)
- 5 Pressure relief valve connection
- 6 Liquid injection (operation without liquid subcooler and with thermostatic expansion valve)
- 7 Refrigerant inlet at liquid subcooler
- 8 Refrigerant outlet at liquid subcooler
- 9 Suction gas line
- 10 Sight glass
- 11 Load suspension points
- 12 Plug for screwed cable gland
- 13 Cable bushing (for cables  $\varnothing$  9-17 mm) (only ECOLITE)

Dimensions can show tolerances according to EN ISO 13920-B.