

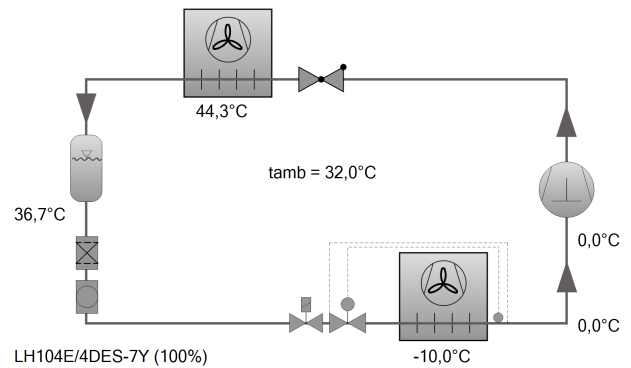

## Selection: Condensing Units

### Input Values

Unit type	LH104E/4DES-7Y
Series	Standard
Refrigerant	R449A
Reference temperature	Dew point temp.
Evaporating SST	-10,00 °C
Ambient temp.	32,0 °C
Suct. gas superheat	10,00 K
Useful superheat	100%
Operating mode	Auto
Power supply	400V-3-50Hz
Capacity control	100%



### Result

Unit type	<b>LH104E/4DES-7Y-40S</b>
Capacity steps	100%
Cooling capacity	12,46 kW
Evaporator capacity	12,46 kW
Power input	5,94 kW
Current (400V)	9,85 A
Voltage range	380-420V
Mass flow	306 kg/h
Condensing SDT	44,3 °C
Liquid subcooling	3,00 K
Operating mode	Standard

Condensing unit with the selected refrigerant is only intended for evaporating temperatures above -30°C within the EU due to the legal requirements from the regulation (EU) 2015/1095. Permissible condensing unit-refrigerant combinations see Declaration of Conformity AC-500  
Tentative Data.  
Power input including fan power absorption

### Application Limits 1 LH104E/4DES-7

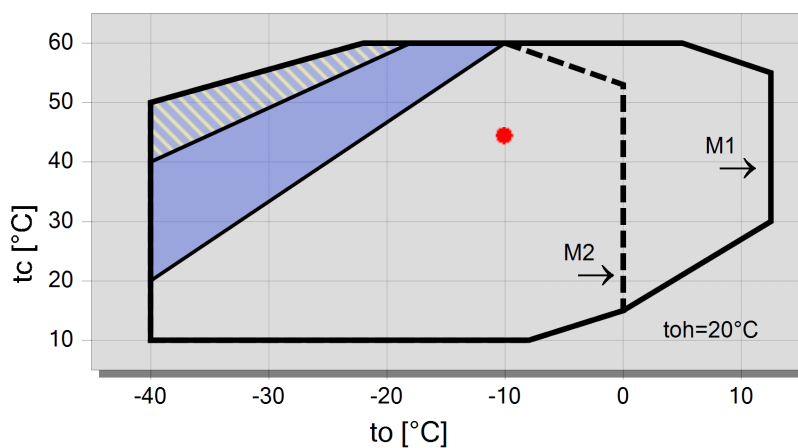

#### Legend

- additional cooling & suction gas superheat ≤20K
- additional cooling
- M1: motor 1
- M2: motor 2
- A



## Technical Data: LH104E/4DES-7Y

### Dimensions and Connections

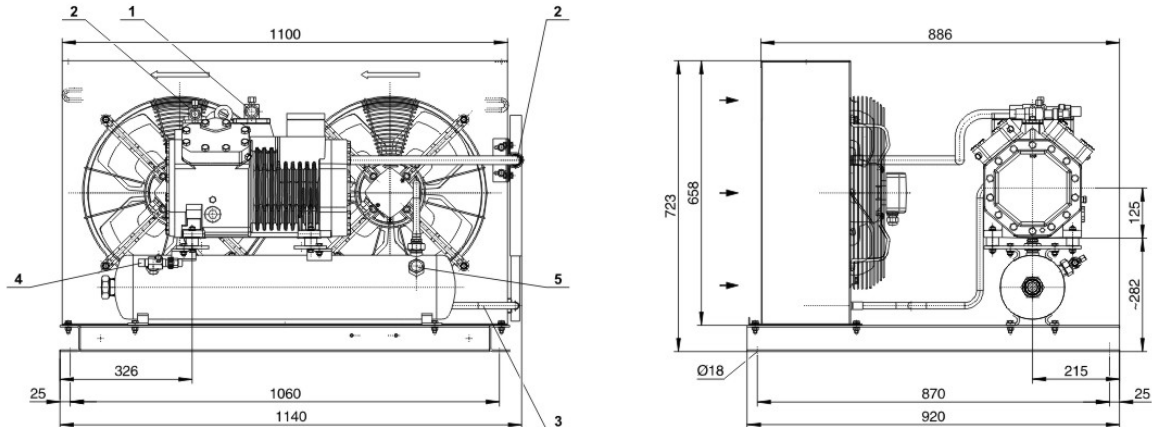

### Technical Data

#### Technical Data

Weight	188 kg
Total width	1140 mm
Total depth	920 mm
Total height	723 mm
Connection suction line	28 mm - 1 1/8"
Connection liquid line	16 mm - 5/8"
Voltage (50Hz, more on request)	230V-1-50Hz (Standard)
Current / Power consumption of each fan (50Hz)	1,5 A / 330 W
Air flow condenser 50Hz	9000 m <sup>3</sup> /h
Voltage (60Hz, more on request)	230V-1-60Hz (Standard)
Current / Power consumption of each fan (60Hz)	1,8 A / 330 W
Air flow condenser 60Hz	9000 m <sup>3</sup> /h
Coil Volume	1,8 dm <sup>3</sup>

#### Extent of delivery (Standard)

Liquid receiver with shut-off valve	Standard
Discharge gas line	Standard
Connection for pressure relief valve	Standard
Fans: Number	2 x EC
Protective charge	Standard

#### Available Options

ECOLINE with VARISTEP (CR11)	100 .. 10%
Second capacity regulator (CR11)	Option
Condenser with improved corrosion protection, plastic coated fins or copper fins	Option
Oil separator with check valve	Option
Accessory pack (HP/LP switches, complete wiring, liquid line + filter drier + sight glass)	Option
Wiring of electrical components to terminal box or junction box	Option
Adjustable high and low pressure switch	Option
Speed control fan, control range high pressure	5 .. 15 bar // 8 .. 25 bar
Discharge gas temperature sensor	Option
Oil level monitoring	OLC-K1
Oil heater	Option
Check valve	Option
Liquid receiver with larger volume	Option
Weather protection housing, mounting kit	Option

#### Sound measurement

Data of compressors: see compressor program

#### Max. refrigerant charge 90% at 20°C / 68°F

Receiver type (Standard)	F152H
R22	16,3 kg
R134a	16,5 kg
R407C	15,6 kg
R404A/R507A	14,4 kg



R407A	15,8 kg
R407F	15,4 kg
R448A	15 kg
R449A	15,1 kg
R450A	16,1 kg
R454C	14,3 kg
R455A	14,2 kg
R513A	16,5 kg
R1234yf	15 kg
R1234ze	15,9 kg
Receiver type (Option)	F302H
R22	32,7 kg
R134a	33,1 kg
R407C	31,3 kg
R404A/R507A	28,8 kg



## Condensing Units

**Motor 1** = e.g. LH..E/4TES-12 with 12 "HP", primary for air-conditioning (e.g. R22,R407C) and medium temperature application (e.g. R134a, R407F, R407A, R404A, R507A, R22) and air-conditioning with R134a at high ambient temperatures.

**Motor 2** = e.g. LH..E/4TES-9 with 8 "HP", for medium and low temperature application (e.g. R134a, R407F, R407A, R404A, R507A, R22) and air-conditioning with R134a.

For more information concerning the application range use the "limits" button.

### Operation modes for LH..E/4VES-7 to LH../6HE-28 with R22

CIC = liquid injection with low temperature application, suction gas cooled motor

### Specifications for sound emission

The data are based on 50 Hz operation.

Soundpressure: Data are valid for free field conditions with a block-shaped reference area in a distance of 10m.

For further information see technical information for sound data.

### Legend of connection positions according to "Dimensions":

- 1 Suction gas valve
- 2 Discharge gas line
- 3 Condensate line
- 4 Refrigerant outlet (liquid line)
- 5 Pressure relief valve connection
- 6 Liquid injection (operation without liquid subcooler and with thermostatic expansion valve)
- 7 Refrigerant inlet at liquid subcooler
- 8 Refrigerant outlet at liquid subcooler
- 9 Suction gas line
- 10 Sight glass
- 11 Load suspension points
- 12 Plug for screwed cable gland
- 13 Cable bushing (for cables  $\varnothing$  9-17 mm) (only ECOLITE)

Dimensions can show tolerances according to EN ISO 13920-B.