

Date 11/4/2023
 For the attention of: frigotehnie.ro
 Reference
 Operator Kubitech S.R.L.



COMMERCIAL UNIT COOLER:CUBIC
Type: E45HC 4813 E 7
N. units: 1

Refriger (u) 2021 Ver. 2.2.2.385 - PRICE LIST 1/1/2023

| | | | |
|--|---|---------------|---|
| Inlet air temp. (room) | [°C] | | 0,0 |
| Room relative humidity | [%] | | 85 |
| Refrigerant | | | R449A |
| Altitude | [m] | | 0 |
| Residual static pressure | [Pa] | | 0 |
| DT1 needed for unit cooler (Mean) | [K] | | 10,0 |
| Connection 230V-1PH-50Hz | | | |
| Actual capacity | [W] | | 13.000 |
| Air flow | [m3/h] | | 5.100,0 |
| Air throw | [m] | | 24 |
| Outlet air temperature | [°C] | | -5,2 |
| Evaporating temp (Mean) | [°C] | | -10,0 |
| DT superheating (Dew) | [K] | | 5,0 |
| Temp. before expansion valve | [°C] | | 29,6 |
| DT1 (Mean) | [K] | | 10,0 |
| Fluid pressure drop | [K] | | 1,4 |
| RC factor (Sensible capacity/Total capacity) | [%] | | 74,3 |
| Energy efficiency class | | | C (2014 thresholds) |
| Fan motor consumpt. | [W] | | 430 |
| Power draw | [A] | | 2,2 |
| Max fan absorbed current* | [A] | | 2,2 |
| Fan speed | [1/min] | | 1350 |
| Sound pressure level (5 m) 5 | [dB(A)@5m] | | 53 |
| Sound Power Level | [dB(A)] | | 78 |
| Electric defrost (230 V) | [W] | | 5.950 |
| N° Fans | [mm] | 1 x 450 | Weight [kg] 90 |
| Poles | [n] | 4 | Connections in [n] x [mm] 1 x 16 |
| Fin spacing | [mm] | 7 | Connections out [n] x [mm] 1 x 35 |
| Internal volume | [dm3] | 7,7 | Drain tray connection ["] 1" 1/4 |
| Surface | [m2] | 33,6 | Overall dimensions [mm] 1.300 x 580 x 685 |
| Max Working pressure | [bar] | 24,0 | |
| Casing material | Powder coated galvanized steel RAL 9003 | Fin material | Al |
| Header material | Cu | Tube material | Cu |

* Refer to LU-VE S.p.A. instruction manuals for details, data and standards. Noise level in 5m free field. The current may increase according to temperature frost quantity, external static pressure. The weight and dimensions are not valid for all possible configurations. All fans are ErP 2015-compliant (Directive 2009/125/EC Energy-related products). LU-VE S.p.A. reserves the right to modify and correct at any time, with or without notice, the specifications and prices listed in the Refriger software.

The certified performances and conditions in this software are in line with performances and conditions published on EUROVENT website. Those performances can be verified in www.eurovent-certification.com.

The EUROVENT certification refers to the unit in standard configuration, additional options may impact on declared reference performance.

The shape of connections is for illustrative purposes only.

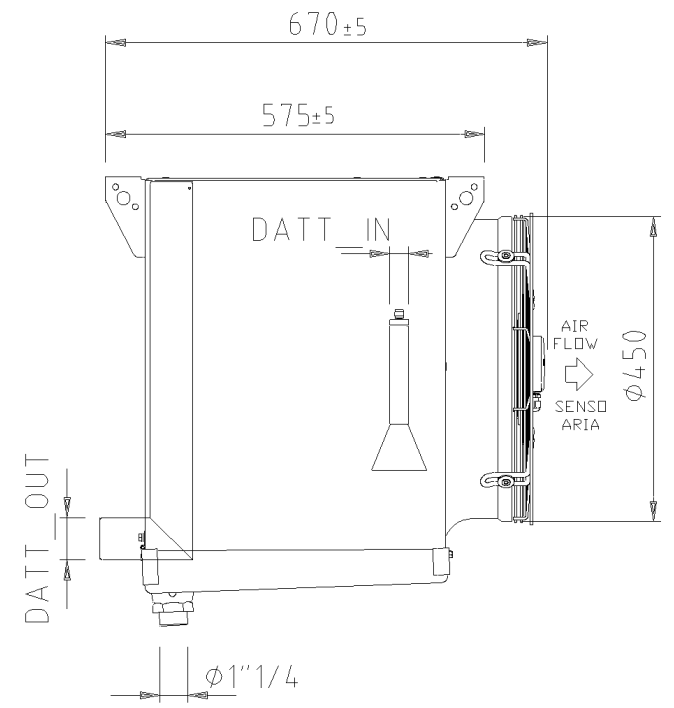
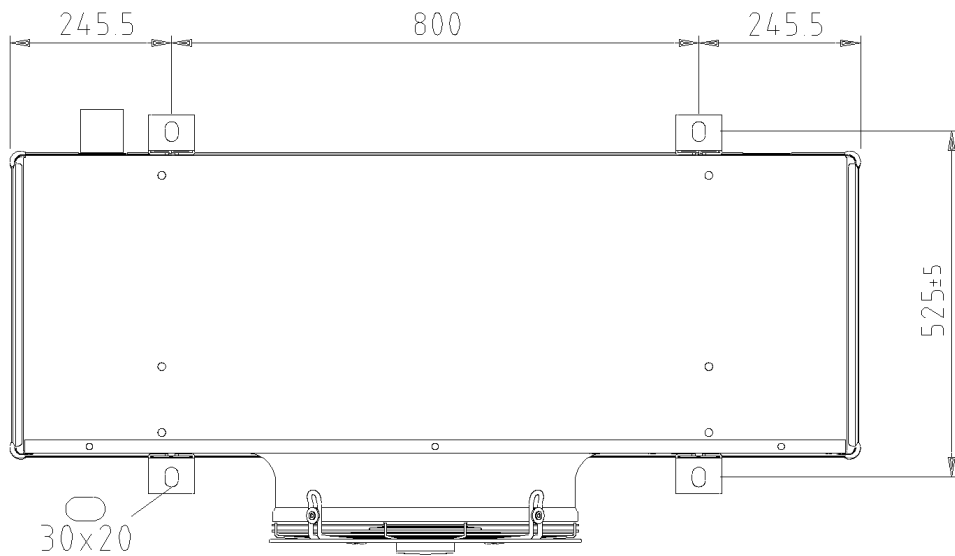
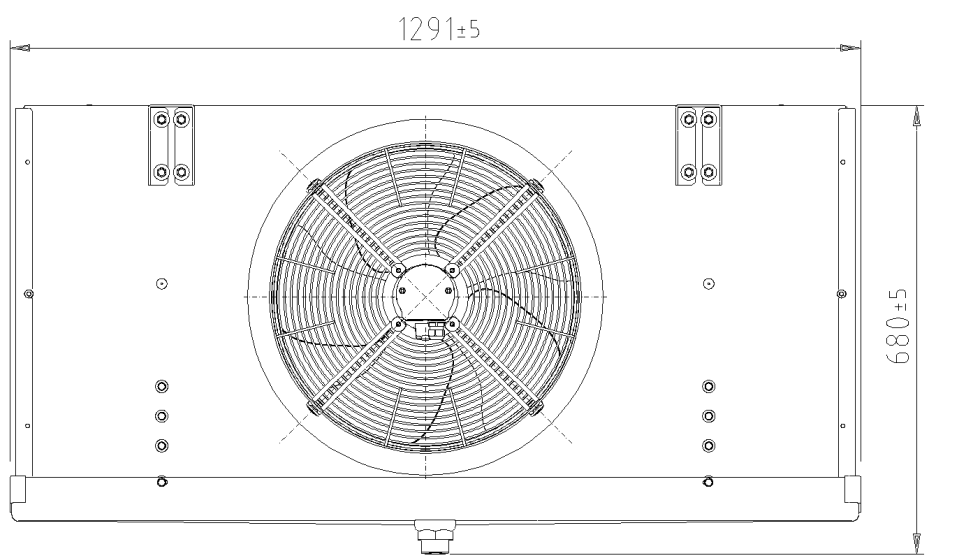

Standard unit without accessories. For the connections please refer to the data sheet.

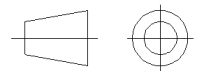
| | |
|---|---|
| Date 01-12-19 | Type: E45HC 4813 E 7 Code: 10217288 |
| Scale 1:1 |  |
|  | |