



ZANOTTI Spa
Via M.L. King, 30
46020 - Pegognaga (MN) - ITALY
Tel. +39 0376 5551
Fax +39 0376 536554
info@zanotti.com

Detalii tehnice

Versiune 2.2

Model:

Categorie:

MGM110EA11XA

GM

Date Tehnice

| Caracteristici | U.M | Valoare |
|----------------------|------------|---------------|
| Temperatura de lucru | °C | +10 ÷ -5 |
| Mod Start | | Direct |
| Voltaj | Volt-Ph-Hz | 220-230/1~/50 |
| Absorbție Nominala | kW* | 0,90 |
| Absorbție Nominala | Amp* | 5,20 |
| Curent de varf | Amp | 38,0 |
| Curent Maxim | Amp | 10,8 |
| Refrigerant | | R134a |
| | GWP | 1430 |
| Defrost | | Gaze calde |
| Masa | Kg | 64 |

Compresor

| | | |
|-----------------|----|---------|
| Mod | | Ermetic |
| Putere Nominala | kW | 0,9 |

Condensator

| | | |
|-------------|------|-----|
| Flux de aer | m³/h | 600 |
|-------------|------|-----|

Vaporizator

| | | |
|-----------------|------|-----|
| Flux de aer | m³/h | 600 |
| Lungime jet aer | m** | 4 |

| | | |
|--------------|--|---|
| PED Category | | 0 |
|--------------|--|---|



Date Putere

| Tc °C | Ta °C | P watt | P Kcal/h | V100 m³ | V80 m³ | V60 m³ |
|-------|-------|--------|----------|---------|--------|--------|
| | 20 | 2133 | 1834 | 21 | 19 | 17 |
| | 25 | 1984 | 1706 | 18 | 16 | 15 |
| 10 | 30 | 1888 | 1624 | 18 | 16 | 15 |
| | 35 | 1807 | 1554 | 17 | 15 | 14 |
| | 40 | 1701 | 1463 | 16 | 15 | 13 |
| | 45 | 1533 | 1318 | 14 | 13 | 12 |
| | 20 | 1801 | 1549 | 17 | 15 | 14 |
| | 25 | 1677 | 1442 | 15 | 14 | 12 |
| 5 | 30 | 1585 | 1363 | 14 | 13 | 12 |
| | 35 | 1507 | 1296 | 13 | 12 | 11 |
| | 40 | 1423 | 1224 | 12 | 11 | 10 |
| | 45 | 1314 | 1130 | 11 | 10 | 9,1 |
| | 20 | 1583 | 1361 | 14 | 13 | 12 |
| | 25 | 1443 | 1241 | 12 | 11 | 10 |
| 0 | 30 | 1351 | 1162 | 11 | 10 | 9,1 |
| | 35 | 1283 | 1103 | 11 | 10 | 9,1 |
| | 40 | 1216 | 1046 | 9,8 | 8,9 | 8,1 |
| | 45 | 1127 | 969 | 8,7 | 7,9 | 7,2 |
| | 20 | 1355 | 1165 | 11 | 10 | 9,1 |
| | 25 | 1217 | 1047 | 9,8 | 8,9 | 8,1 |
| -5 | 30 | 1128 | 970 | 8,7 | 7,9 | 7,2 |
| | 35 | 1068 | 918 | 8,1 | 7,4 | 6,7 |
| | 40 | 1012 | 870 | 7,5 | 6,8 | 6,2 |
| | 45 | 940 | 808 | 6,7 | 6,1 | 5,6 |

Calcul Putere si Volum

| | | |
|------|------------------------------------|--------|
| Ta | <input type="text" value="35,0"/> | °C |
| Tc | <input type="text" value="0,0"/> | °C |
| PF | <input type="text" value="1.283"/> | Watt |
| | <input type="text" value="1.103"/> | Kcal/h |
| V100 | <input type="text" value="11,0"/> | m³ |
| V80 | <input type="text" value="10,0"/> | m³ |
| V60 | <input type="text" value="9,1"/> | m³ |

* Functionare normala: 0 ÷ +30°C

** Utilizati lungimea jetului de aer ca baza. Lungimea jetului de aer depinde de multi factori precum, inaltimea camerei, depozitarea marfurilor, amplasarea vaporizatoarelor, etc.

Tc: Temp Camera. - Ta:Temp Exterioara.

P: Putere frigorifica - V: Volum de camera recomandat

L'immagine è datata e potrebbe presentare alcune differenze rispetto all'unità attuale. La aggiorneremo il prima possibile.
The picture is old and it could have some differences from the current unit. We will update it as soon as possible.

Dimensioni - Dimensions - Dimensions
Abmessungen - Dimensiones

GM1

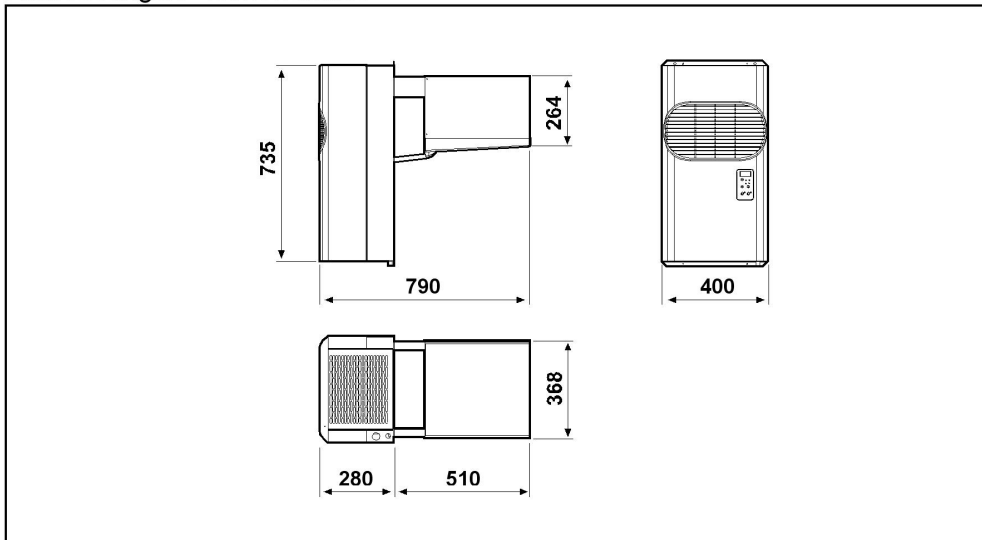

Schema di montaggio - Mounting scheme - Schema de montage
Montageschema - Esquema de montaje

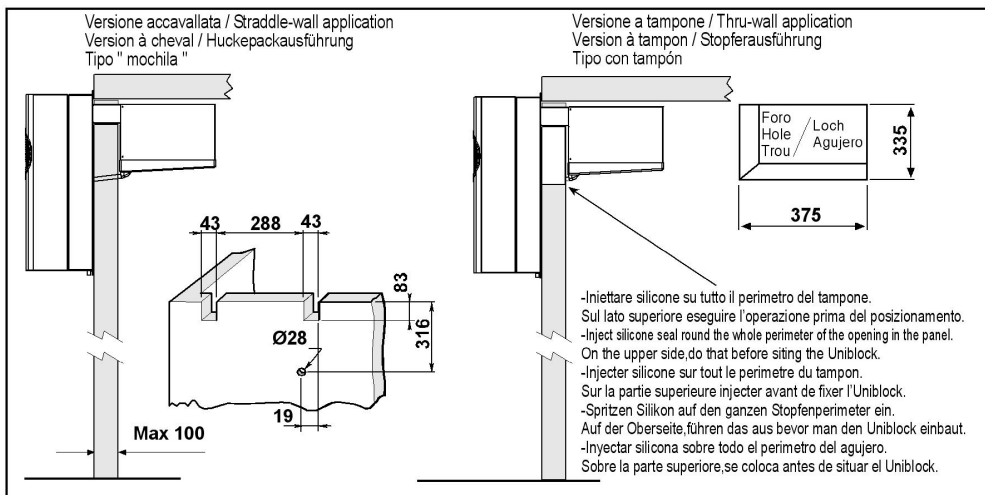

- * Raccomandazioni in sede di installazione e per il controllo fornite sul manuale di installazione
- * To be advised at time of order for factory installation and operating instructions
- * Recommendations au moments d'installations et pour le contrôle fournis sur le manuel d'installation
- * Empfehlungen für die Installationsphase und zur Kontrolle, die im Handbuch zur Installation enthalten sind
- * Por cuanto respecta a recomendaciones de instalaciòn y control ver manual de instalaciòn

Massa e misure imballi - Packing mass and dimensions - Masse et dimensions emballages
Verpackungsmasse und-abmessungen - Masa y medidas del embalaje

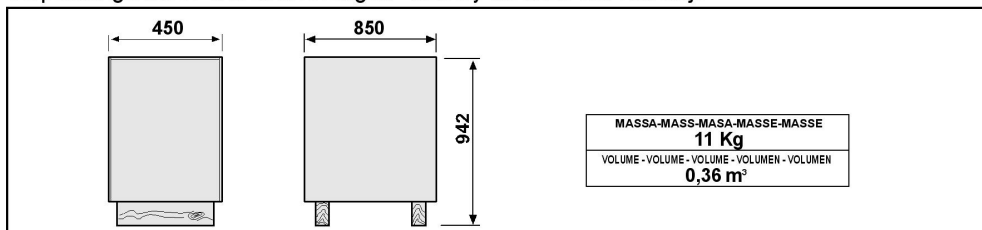

ZANOTTI S.p.A.