



Compressor
Voltage Code : TZ

AG2513P-TZ

Low Temp. Commercial (BP)

400V 3~ 50Hz / 440V 3~ 60 Hz

R452A / R404A / R455A / R454C

AG2513P-TZ1A

Conditions	Frequency	Nominal Cooling Capacity		Sound Power ISO3745 / ISO 3743-1
		Watts	BTU/h	
CECOMAF / R452A	50 Hz / 60 Hz	1964 / 2439	6699 / 8317	78 dBA
CECOMAF / R404A	50 Hz / 60 Hz	2087 / 2584	7115 / 8811	78 dBA
CECOMAF / R455A	50 Hz / 60 Hz	1509 / 1892	5145 / 6450	78 dBA
CECOMAF / R454C	50 Hz / 60 Hz	1431 / 1795	4881 / 6121	78 dBA

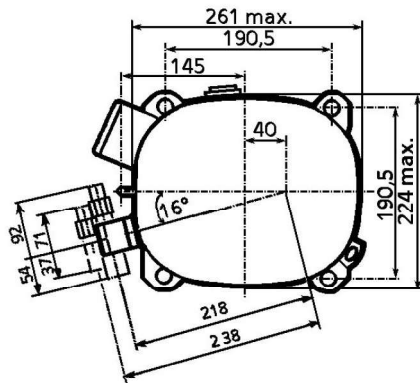
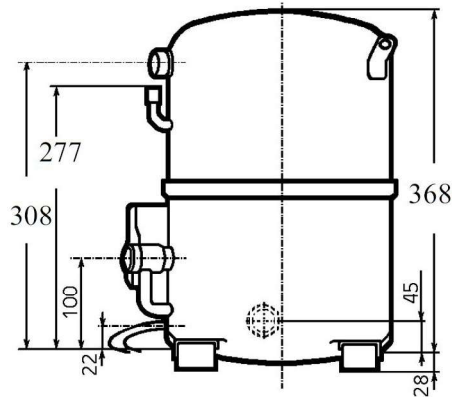

* CECOMAF : T°Cond. 55.0°C / T°Evap. -25.0°C / T°Return gas temp.. 32.0°C
T°Subcooling. 0.0K

Certificates :

Displacement (cc)	100,7
Net Weight (Kg)	44.0
Oil Quantity (cc)	1760.0
Oil Type	Polyolester
Expansion Device	Capillary_Tube/Expansion_Valve
Cooling	Fan
Main Winding (Ohm)	4.6
Current	
RLA (A)	4,3 4,4
MCC (A)	8,5 8,9
LRA (A)	42 43
Electrical Equipment	TRI
Overload	Interne
Refrigerating connection for	
Suction Tube	22,2 (7/8")
Discharge Tube	15,9 (5/8")
Process Tube	6,35 (1/4")

Note : Tecumseh reserves the right to change information contained in this document without notification.



AG2513P-TZ	Tension TZ : 400V 3~ 50Hz / 440V 3~ 60 Hz
-------------------	--

Les performances sont données dans les **conditions CECOMAF** :
 Condition Dew
 The performance data are in **CECOMAF conditions** :
 Dew Condition

Gaz aspirés : 32.0 °C
 Sous refroidissement : 0.0 K
 Return gas : 32.0 °C
 Subcooling : 0.0 K

50 Hz R452A

N°3571

4 T condensation	5 T évaporation	(°C)	-40	-35	-30	-25	-20	-15	-10
30	1 P frigorifique	(Watt)	1360	2126	3095	4299	5766	7528	9614
	2 P absorbée	(W)	1258	1587	1921	2262	2612	2974	3349
	3 I absorbée	(A)	3.04	3.35	3.70	4.10	4.54	5.03	5.57
40	1 P frigorifique	(Watt)		1486	2312	3339	4597	6118	7932
	2 P absorbée	(W)		1460	1851	2254	2672	3106	3558
	3 I absorbée	(A)		3.18	3.61	4.09	4.60	5.17	5.77
50	1 P frigorifique	(Watt)			1563	2405	3447	4719	6253
	2 P absorbée	(W)			1693	2153	2631	3132	3655
	3 I absorbée	(A)			3.43	3.98	4.57	5.20	5.87
60	1 P frigorifique	(Watt)				1549	2366	3382	4628
	2 P absorbée	(W)				1958	2492	3052	3641
	3 I absorbée	(A)				3.77	4.43	5.13	5.87

60 Hz R452A

N°3571

4 T condensation	5 T évaporation	(°C)	-40	-35	-30	-25	-20	-15	-10
30	1 P frigorifique	(Watt)	1713	2662	3806	5178	6811	8734	10981
	2 P absorbée	(W)	1546	1957	2351	2744	3156	3603	4103
	3 I absorbée	(A)	2.90	3.30	3.73	4.21	4.72	5.28	5.88
40	1 P frigorifique	(Watt)		1853	2876	4098	5551	7267	9279
	2 P absorbée	(W)		1786	2281	2768	3266	3793	4367
	3 I absorbée	(A)		3.08	3.63	4.22	4.86	5.54	6.26
50	1 P frigorifique	(Watt)			1933	2993	4255	5752	7517
	2 P absorbée	(W)			2051	2649	3250	3873	4536
	3 I absorbée	(A)			3.36	4.07	4.82	5.62	6.46
60	1 P frigorifique	(Watt)				1889	2948	4215	5724
	2 P absorbée	(W)				2362	3082	3817	4585
	3 I absorbée	(A)				3.75	4.62	5.54	6.50

1 = cooling capacity 2 = power input 3 = current 4 = condensing temperature 5 = evaporating temperature

Nota : Tecumseh se réserve le droit de modifier les informations contenues dans ce document sans préavis.

Note : Tecumseh reserves the right to change information contained in this document without notification.

© 2025 Tecumseh Products Company
All rights reserved



AG2513P-TZ	Tension TZ : 400V 3~ 50Hz / 440V 3~ 60 Hz
-------------------	--

Les performances sont données dans les **conditions CECOMAF** :
 Condition Dew

The performance data are in **CECOMAF conditions** :
 Dew Condition

Gaz aspirés : 32.0 °C
 Sous refroidissement : 0.0 K

Return gas : 32.0 °C
 Subcooling : 0.0 K

50 Hz R404A

N°3566

4 T condensation	5 T évaporation	(°C)	-40	-35	-30	-25	-20	-15	-10
30	1 P frigorifique	(Watt)	1496	2317	3348	4611	6132	7935	10045
	2 P absorbée	(W)	1387	1755	2125	2498	2876	3257	3643
	3 I absorbée	(A)	3.36	3.71	4.09	4.52	4.99	5.50	6.04
40	1 P frigorifique	(Watt)		1620	2491	3559	4849	6386	8195
	2 P absorbée	(W)		1631	2057	2492	2937	3392	3858
	3 I absorbée	(A)		3.55	4.02	4.52	5.06	5.65	6.27
50	1 P frigorifique	(Watt)			1686	2559	3618	4889	6398
	2 P absorbée	(W)			1896	2393	2905	3433	3978
	3 I absorbée	(A)			3.84	4.42	5.04	5.70	6.40
60	1 P frigorifique	(Watt)				1637	2466	3471	4681
	2 P absorbée	(W)				2186	2765	3366	3990
	3 I absorbée	(A)				4.21	4.91	5.65	6.43

60 Hz R404A

N°3566

4 T condensation	5 T évaporation	(°C)	-40	-35	-30	-25	-20	-15	-10
30	1 P frigorifique	(Watt)	1896	2902	4111	5548	7234	9192	11446
	2 P absorbée	(W)	1717	2170	2600	3026	3465	3935	4455
	3 I absorbée	(A)	3.22	3.66	4.13	4.64	5.18	5.77	6.39
40	1 P frigorifique	(Watt)		2017	3098	4373	5866	7600	9598
	2 P absorbée	(W)		1993	2533	3061	3594	4149	4746
	3 I absorbée	(A)		3.43	4.03	4.67	5.35	6.06	6.80
50	1 P frigorifique	(Watt)			2074	3176	4463	5961	7693
	2 P absorbée	(W)			2295	2943	3587	4247	4939
	3 I absorbée	(A)			3.76	4.52	5.33	6.16	7.04
60	1 P frigorifique	(Watt)				2005	3076	4326	5781
	2 P absorbée	(W)				2642	3416	4198	5004
	3 I absorbée	(A)				4.20	5.13	6.09	7.10

1 = cooling capacity 2 = power input 3 = current 4 = condensing temperature 5 = evaporating temperature

Nota : Tecumseh se réserve le droit de modifier les informations contenues dans ce document sans préavis.

Note : Tecumseh reserves the right to change information contained in this document without notification.

© 2025 Tecumseh Products Company
All rights reserved



AG2513P-TZ	Tension TZ : 400V 3~ 50Hz / 440V 3~ 60 Hz
-------------------	--

Les performances sont données dans les **conditions CECOMAF** :
 Condition Dew
 The performance data are in **CECOMAF conditions** :
 Dew Condition

Gaz aspirés : 32.0 °C
 Sous refroidissement : 0.0 K
 Return gas : 32.0 °C
 Subcooling : 0.0 K

50 Hz R455A

N°3441

4 T condensation	5 T évaporation	(°C)	-40	-35	-30	-25	-20	-15	-10
30	1 P frigorifique	(Watt)	940	1628	2507	3607	4955	6578	8505
	2 P absorbée	(W)	979	1273	1565	1855	2144	2433	2724
	3 I absorbée	(A)	3.04	3.22	3.46	3.75	4.09	4.48	4.93
40	1 P frigorifique	(Watt)	460	1062	1832	2798	3988	5428	7148
	2 P absorbée	(W)	800	1145	1497	1857	2226	2604	2992
	3 I absorbée	(A)	2.90	3.14	3.42	3.77	4.16	4.61	5.10
50	1 P frigorifique	(Watt)		472	1121	1941	2961	4207	5709
	2 P absorbée	(W)		900	1303	1724	2162	2619	3097
	3 I absorbée	(A)		2.94	3.28	3.67	4.12	4.61	5.16
60	1 P frigorifique	(Watt)			419	1081	1918	2959	4232
	2 P absorbée	(W)			966	1437	1936	2463	3020
	3 I absorbée	(A)			3.02	3.46	3.96	4.51	5.11

60 Hz R455A

N°3441

4 T condensation	5 T évaporation	(°C)	-40	-35	-30	-25	-20	-15	-10
30	1 P frigorifique	(Watt)	1191	2099	3169	4428	5902	7616	9596
	2 P absorbée	(W)	1182	1545	1906	2266	2622	2974	3321
	3 I absorbée	(A)	2.67	2.96	3.29	3.65	4.05	4.48	4.95
40	1 P frigorifique	(Watt)	413	1286	2298	3476	4844	6429	8257
	2 P absorbée	(W)	860	1317	1774	2232	2689	3145	3599
	3 I absorbée	(A)	2.41	2.81	3.25	3.72	4.22	4.76	5.34
50	1 P frigorifique	(Watt)		392	1342	2434	3692	5144	6815
	2 P absorbée	(W)		929	1495	2063	2634	3205	3777
	3 I absorbée	(A)		2.44	2.99	3.56	4.18	4.83	5.51
60	1 P frigorifique	(Watt)			341	1342	2486	3801	5313
	2 P absorbée	(W)			1028	1719	2415	3115	3817
	3 I absorbée	(A)			2.51	3.20	3.92	4.68	5.47

1 = cooling capacity 2 = power input 3 = current 4 = condensing temperature 5 = evaporating temperature

Nota : Tecumseh se réserve le droit de modifier les informations contenues dans ce document sans préavis.

Note : Tecumseh reserves the right to change information contained in this document without notification.

© 2025 Tecumseh Products Company
All rights reserved



AG2513P-TZ	Tension TZ : 400V 3~ 50Hz / 440V 3~ 60 Hz
-------------------	--

Les performances sont données dans les **conditions CECOMAF** :
 Condition Dew

The performance data are in **CECOMAF conditions** :
 Dew Condition

Gaz aspirés : 32.0 °C
 Sous refroidissement : 0.0 K

Return gas : 32.0 °C
 Subcooling : 0.0 K

50 Hz R454C

N°3440

4 T condensation	5 T évaporation	(°C)	-40	-35	-30	-25	-20	-15	-10
30	1 P frigorifique	(Watt)	889	1539	2365	3387	4629	6112	7857
	2 P absorbée	(W)	938	1220	1498	1769	2035	2294	2547
	3 I absorbée	(A)	2.91	3.09	3.31	3.57	3.88	4.23	4.61
40	1 P frigorifique	(Watt)	431	1008	1739	2647	3754	5082	6654
	2 P absorbée	(W)	760	1091	1426	1765	2108	2453	2802
	3 I absorbée	(A)	2.76	2.99	3.26	3.58	3.94	4.34	4.78
50	1 P frigorifique	(Watt)		443	1064	1842	2800	3959	5343
	2 P absorbée	(W)		853	1237	1634	2044	2466	2900
	3 I absorbée	(A)		2.78	3.11	3.48	3.89	4.35	4.84
60	1 P frigorifique	(Watt)			390	1022	1814	2789	3969
	2 P absorbée	(W)			914	1360	1828	2318	2829
	3 I absorbée	(A)			2.86	3.28	3.74	4.24	4.79

60 Hz R454C

N°3440

4 T condensation	5 T évaporation	(°C)	-40	-35	-30	-25	-20	-15	-10
30	1 P frigorifique	(Watt)	1126	1985	2988	4158	5514	7076	8866
	2 P absorbée	(W)	1133	1481	1825	2161	2488	2804	3106
	3 I absorbée	(A)	2.56	2.84	3.15	3.49	3.84	4.23	4.63
40	1 P frigorifique	(Watt)	386	1221	2181	3287	4559	6019	7686
	2 P absorbée	(W)	817	1254	1690	2122	2547	2964	3370
	3 I absorbée	(A)	2.29	2.68	3.09	3.53	4.00	4.49	5.00
50	1 P frigorifique	(Watt)		367	1276	2310	3491	4840	6377
	2 P absorbée	(W)		880	1418	1956	2490	3018	3538
	3 I absorbée	(A)		2.31	2.83	3.38	3.95	4.54	5.16
60	1 P frigorifique	(Watt)			315	1270	2352	3582	4983
	2 P absorbée	(W)			973	1627	2280	2930	3575
	3 I absorbée	(A)			2.38	3.03	3.70	4.40	5.12

1 = cooling capacity 2 = power input 3 = current 4 = condensing temperature 5 = evaporating temperature

Nota : Tecumseh se réserve le droit de modifier les informations contenues dans ce document sans préavis.

Note : Tecumseh reserves the right to change information contained in this document without notification.

© 2025 Tecumseh Products Company
All rights reserved