



ZANOTTI Spa
 Via M.L. King, 30
 46020 - Pegognaga (MN) - ITALY
 Tel. +39 0376 5551
 Fax +39 0376 536554
 info@zanotti.com

Technical specifications

Version 1.35

Model: **BGM32002F** Class: **Uniblock GM**

Technical data

Characteristics	M.U.	Value
Working temperature	°C	-15 ÷ -25
Starting mode		Direct
Voltage	Volt-Ph-Hz	400/3N~/50
Rated input	kW*	2.20
Rated input	Amp*	4.90
Peak current	Amp	41.0
Max current	Amp	11.1
Refrigerant		R404A
Defrost		Hot gas
Mass	Kg	105

Compressor

Type		Hermetic
Nominal power	kW	1.5

Condenser

Air flow	m³/h	1500
----------	------	------

Evaporator

Air flow	m³/h	1800
Air throw	m**	10

PED Category		0
--------------	--	---



Power data

Tc °C	Ta °C	P watt	P Kcal/h	V120 m³	V100 m³	V80 m³
-15	20	3316	2852	44	39	34
	25	3087	2655	40	36	31
	30	2858	2458	35	31	27
	35	2632	2264	31	28	24
	40	2409	2072	26	23	20
-20	45	2189	1883	22	20	17
	20	2803	2411	34	30	27
	25	2596	2233	30	27	23
	30	2392	2057	26	23	20
	35	2192	1885	22	20	17
-25	40	1995	1716	19	17	15
	45	1803	1551	17	15	13
	20	2324	1999	25	22	20
	25	2142	1842	21	19	16
	30	1964	1689	18	16	14
-25	35	1791	1540	17	15	13
	40	1620	1393	14	12	11
	45	1451	1248	12	11	9.4

Calculation of the refrigerating power and volume

Ta °C

Tc °C

PF Watt

Kcal/h

V120 m³

V100 m³

V80 m³

* When normally running: -20 ÷ +30°C

** Use air throw as a base. Air throw is affected by many factors such as height of room, product storage, location of evaporator, etc.

Tc: Coldroom temp. - Ta: External temp.

P: Refrigerant capacity - V: Recommended cold-room volume

Dimensioni - Dimensions - Dimensions
Abmessungen - Dimensiones

GM3

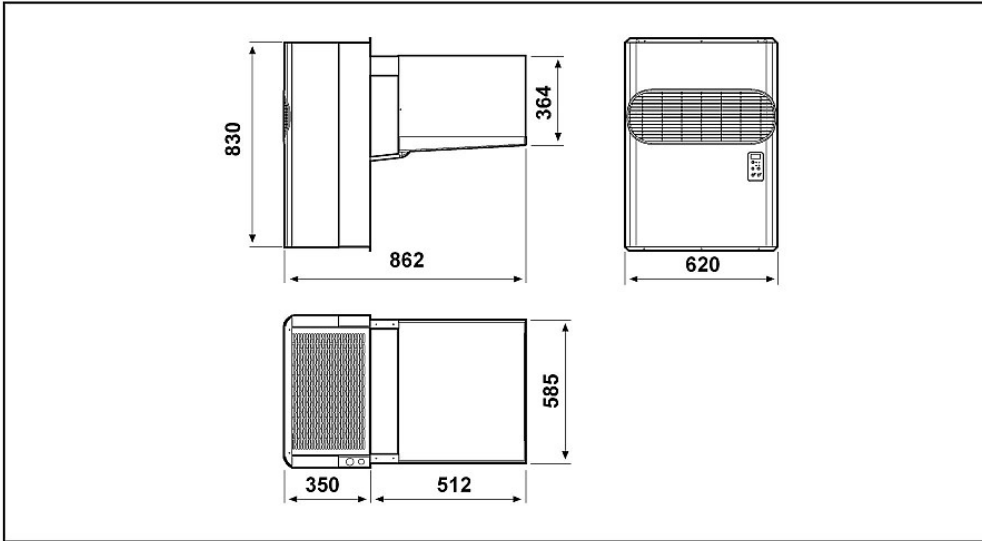

Schema di montaggio - Mounting scheme - Schema de montage
Montageschema - Esquema de montaje

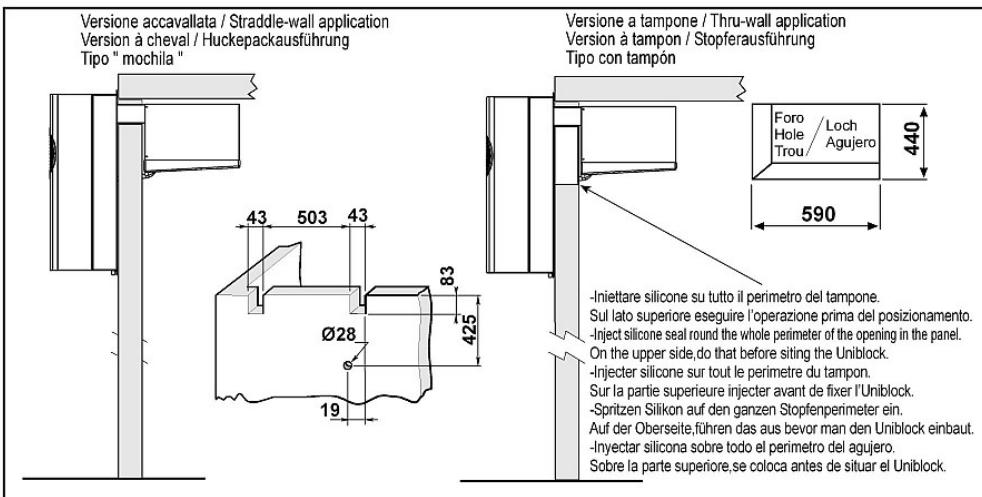

- * Raccomandazioni in sede di installazione e per il controllo fornite sul manuale di installazione
- * To be advised at time of order for factory installation and operating instructions
- * Recommendations au moments d'installations et pour le contrôle fournis sur le manuel d'installation
- * Empfehlungen für die Installationsphase und zur Kontrolle, die im Handbuch zur Installation enthalten sind
- * Por cuanto respecta a recomendaciones de instalación y control ver manual de instalación

Massa e misure imballi - Packing mass and dimensions - Masse et dimensions emballages
Verpackungsmasse und-abmessungen - Masa y medidas del embalaje

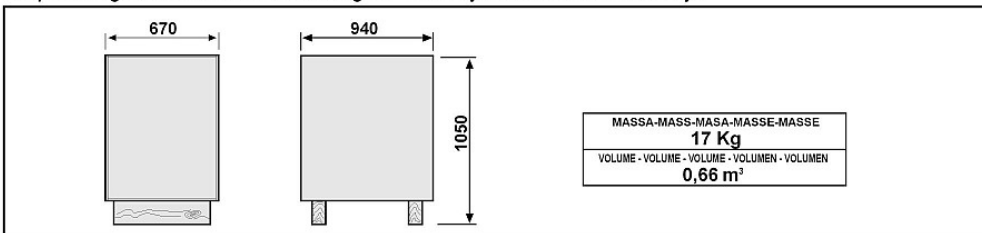

ZANOTTI S.p.A.